

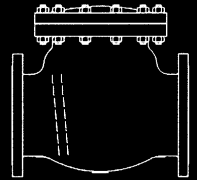

DPV-UK LTD

API 600 Cast Steel Valves

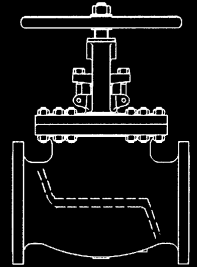
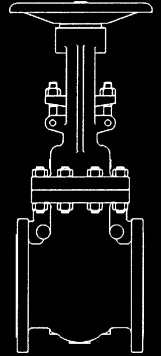

Broadpiece, Mereside, Soham CB7 5EL
Tel: 01353 725 540
Email : Sales@dpv-uk.com
Web: www.dpv-uk.com



API 600 CAST STEEL VALVES

TABLE OF CONTENTS

Page	Title	Page	Title
1	Table of Contents / How To Order	16	Optional Modifications & Auxiliary Connections
2	Company Introduction	17	End Flange Dimensions ANSI Class 150
3	Gate Valve Design Features	18	End Flange Dimensions ANSI Class 300
4	Gate Valve Materials of Construction	19	End Flange Dimensions ANSI Class 600
5	Gate Valve ANSI Class 150 and 300	20	End Flange Dimensions ANSI Class 900
6	Gate Valve ANSI Class 600 to 1500	21	End Flange Dimensions ANSI Class 1500
7	Globe Valve Design Features	22	Pressure-Temp. Ratings ANSI Class 150
8	Globe Valve Materials of Construction	23	Pressure-Temp. Ratings ANSI Class 300
9	Globe Valve ANSI Class 150 and 300	24	Pressure-Temp. Ratings ANSI Class 600
10	Globe Valve ANSI Class 600 to 1500	25	Pressure-Temp. Ratings ANSI Class 900
11	Check Valve Design Features	26	Pressure-Temp. Ratings ANSI Class 1500
12	Check Valve Materials of Construction	27	Shell Material Specifications
13	Check Valve ANSI Class 150 and 300	28	Trim Material Specifications
14	Check Valve ANSI Class 600 to 1500	29	Figure Number Comparison Chart
15	Bevel Gear Operator	30	General Terms and Conditions of Sale

HOW TO ORDER

1 5

ANSI Class

15 = ANSI Class 150
 30 = ANSI Class 300
 60 = ANSI Class 600
 90 = ANSI Class 900
 150 = ANSI Class 1500

1

Valve Type

1 = Gate, OS&Y, RS
 2 = Globe
 3 = Swing Check

2

Shell Material

1 = WC1
 2 = WCB
 3 = CF8M
 3L = CF3M
 4 = CF8
 4L = CF3
 5 = C5
 6 = WC6
 7 = CN7M
 9 = WC9
 C = LCC

F

End Connections

F = Flanged Ends
 B = Butt-Weld Ends
 T = Threaded
 X = Per Customer's Request

Example above, namely DPV Fig. 1512F = ANSI Class 150 Gate Valve, Outside Screw and Yoke, Rising Stem Design, in Cast Carbon Steel ASTM A216 Grade WCB Shell Material with Flanged Ends

COMPANY INTRODUCTION

DPV-UK LTD

Consistent product quality and availability of substantial stocks makes **DPV®** a dependable choice for API 600 cast steel gate, globe, and check valves where total reliability is of the utmost concern.

DPV® manufactures valves to industry standard specifications, or to customer specified requirements, both promptly and economically.

DPV® maintains an extensive quality system which complies with the requirements of major oil companies, industry standards and to the ISO 9000 standard.

DPV® cast steel valves are manufactured in compliance with the requirements of API 600 and pressure tested in accordance with API 598 standard.

Materials of construction include the ASTM A216 and ASTM A352 range of carbon steels, the ASTM A217 range of alloy steels and the ASTM A351 range of corrosion-resistant steels; the pressure containing components being of high integrity castings.

All **DPV®** gate and globe valves can be easily adapted for actuation to most makes of actuators or to suit customer specifications.

Environmentally Friendly Valves

In concert with customers' continual efforts to both reduce the cost of ownership and comply with local environmental requirements, **DPV®** now manufactures a range of low emission valves offering minimum leakage and maximum service life in the stem sealing and bonnet joint areas.

Testing and evaluation criteria is based on EPA method 21, and emission rates lower than 500 ppm during operation are standard for this range of gate, globe and check valves.

GATE VALVE DESIGN FEATURES

- ◆ Plain or One-Piece Flexible Solid Wedge
- ◆ Bolted Bonnet Construction
- ◆ Outside Screw and Yoke
- ◆ Non-Rotating, Rising Stem
- ◆ Manual Operated, Actuation Available
- ◆ Renewable Threaded-In Backseat Bushing
- ◆ Renewable Threaded-In or Welded-In Seat Rings

- ◆ Design : API 600 / API 6D / BS 1414
- ◆ Shell Thickness : API 600 / API 6D / BS 1414
- ◆ Flanged Ends : ANSI B16.5 (Sizes ≤ 24")
MSS SP-44 (Sizes > 24")
API 605 (Sizes > 24")
- ◆ Face-to-Face : ANSI B16.10 / API 6D
- ◆ Testing : API 598 / BS 6755 Part 1

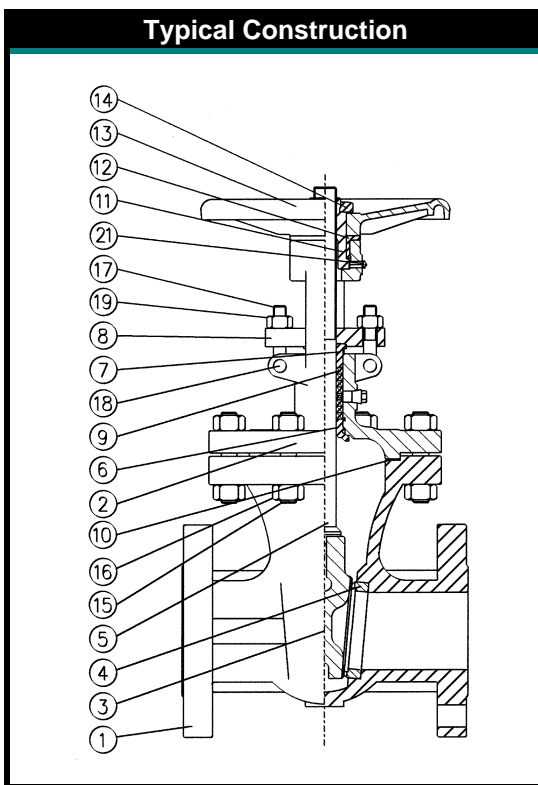

No.	Part Name
1	Body
2	Bonnet
3	Wedge Disc
4	Seat Ring
5	Stem
6	Backseat Bushing
7	Gland Bushing
8	Gland Flange
9	Packing
10	Gasket
11	Yoke Sleeve
12	Retainer Nut
13	Handwheel
14	Handwheel Nut
15 / 16	Stud Bolt / Hex Nut
17	Eyebolt
18	Pin
19	Hex Nut
21	Grease Fitting

Note: Weld end valves available upon request

- ◆ Heavy duty BODY with full port dia. and shell thickness to API / BS standards (where applicable)
- ◆ SEAT RINGS and WEDGE DISC ground and lapped to a mirror finish to provide matching sealing surfaces
- ◆ WEDGE DISC fully guided and precision fitted to ensure tight sealing performance
- ◆ Heat treated stainless steel STEM with precision machined ACME threads for long-lasting service
- ◆ Machined BACKSEAT BUSHING to provide a secondary metal-to-metal stem seal

- ◆ RISING STEM for open/close position indication
- ◆ Austenitic ductile iron YOKE SLEEVE to provide resistance to heat, corrosion and wear
- ◆ Two piece self-aligning GLAND BUSHING and GLAND FLANGE to prevent stem damage
- ◆ High strength alloy steel STUD BOLTS and heavy series HEX NUTS used
- ◆ Large diameter HANDWHEEL for easy operation
- ◆ Grease fitting for YOKE SLEEVE lubrication to minimize operating torque & stem wear

STANDARD MATERIALS OF CONSTRUCTION

Part	ANSI B16.34 Material Group				
	Carbon Steel	C-Mn Steel	Alloy Steel		
	1.1	1.2	1.9	1.10	1.13
Body / Bonnet	A216 Gr. WCB	A352 Gr. LCC	A217 Gr. WC6	A217 Gr. WC9	A217 Gr. C5
Gland Bushing	← 13% Chromium ASTM A182 Gr. F6a →				
Stud Bolts & Hex Nuts	B7 / 2H	L7 / 7	← ASTM A193 Gr. B16 / ASTM A194 Gr. 2H →		
Yoke / Gland Flange	← Carbon Steel →				
Yoke Sleeve	← Austenitic Ductile Iron ASTM A439 Type D2 →				
Retainer Nut	← Carbon Steel →				
Handwheel	← Ductile / Malleable Iron →				
Handwheel Nut	← Carbon Steel →				
Gland Eyebolts & Nuts	← Carbon Steel ASTM A307 Gr. B →				
Part	Corrosion Resistant Steel				
	2.1		2.2		3.17
	A351 Gr. CF8	A351 Gr. CF3	A351 Gr. CF8M	A351 Gr. CF3M	A351 Gr. CN7M
Body / Bonnet	A351 Gr. CF8	A351 Gr. CF3	A351 Gr. CF8M	A351 Gr. CF3M	A351 Gr. CN7M
Gland Bushing	304SS	304L SS	316SS	316L SS	Alloy 20
Stud Bolts & Hex Nuts	← Corrosion Resistant Steel ASTM A193 Gr. B8 / A194 Gr. 8 →				
Yoke / Gland Flange	← Corrosion Resistant Steel →				
Yoke Sleeve	← Austenitic Ductile Iron ASTM A439 Type D2 →				
Retainer Nut	← Carbon Steel →				
Handwheel	← Ductile / Malleable Iron →				
Handwheel Nut	← Carbon Steel →				
Gland Eyebolts & Nuts	← Corrosion Resistant Steel ASTM A193 Gr. B8 / ASTM A194 Gr. 8 →				

Note: Other materials available upon request.

Trim Materials

Part	API Trim No.										
	1	2	5	8	9	10	11	12	13	14	15
Wedge Disc	F6	304SS	HF	F6	Ni-Cu	316SS	Ni-Cu	316SS	Alloy 20	Alloy 20	HF
Seat Ring	F6	304SS	HF	HF	Ni-Cu	316SS	HF	HF	Alloy 20	HF	HF
Stem	F6	304SS	F6	F6	Ni-Cu	316SS	Ni-Cu	316SS	Alloy 20	Alloy 20	304SS
Backseat	F6	304SS	F6	F6	Ni-Cu	316SS	Ni-Cu	316SS	Alloy 20	Alloy 20	304SS
Part	API Trim No.				DPV Trim No.						
	16	17	18	A	B	C	D	E	F	G	H
Wedge Disc	HF	HF	HF	HF	Bronze	F6	304SS	316SS	Ni-Cu	Alloy 20	Bronze
Seat Ring	HF	HF	HF	HF	Bronze	PTFE	PTFE	PTFE	PTFE	PTFE	PTFE
Stem	316SS	347SS	Alloy 20	Ni-Cu	Brass	F6	304SS	316SS	Ni-Cu	Alloy 20	Brass
Backseat	316SS	347SS	Alloy 20	Ni-Cu	Brass	F6	304SS	316SS	Ni-Cu	Alloy 20	Brass

Note: Trim will be supplied either as a base material equal to body with overlay or solid trim at manufacturer's option.

DIMENSIONS

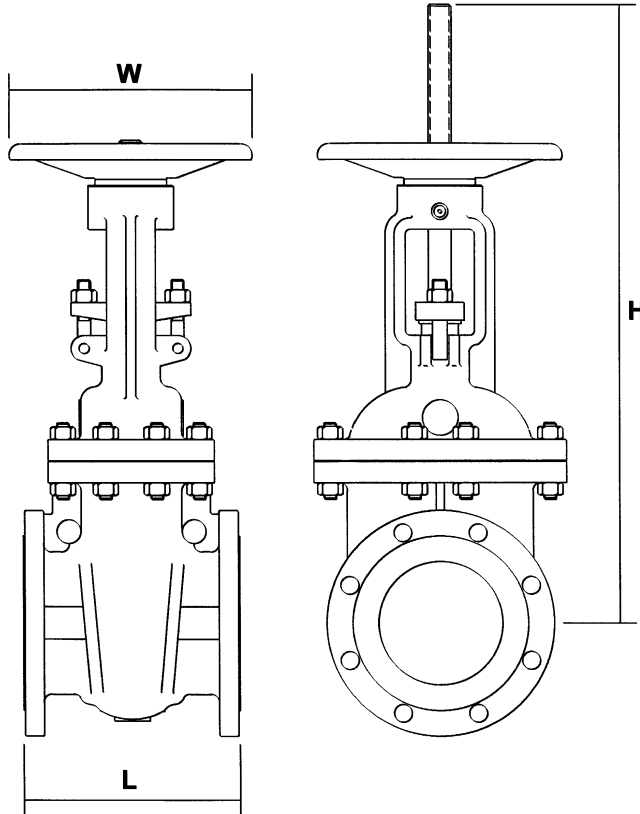

ANSI Class 150

Size	Dimensions (mm)			Approx. Wt.	
	L	H	W	(lb.)	(kg.)
2"	178	388	200	40	18
2½"	191	444	200	54	25
3"	203	497	250	82	37
4"	229	585	250	119	54
5"	254	677	300	157	71
6"	267	765	350	194	88
8"	292	964	350	318	144
10"	330	1,155	400	434	197
12"	356	1,386	450	657	298
14"	381	1,535	500	895	406
16"	406	1,811	600	1,155	524
18"	432	2,009	600	1,588	720
20"	457	2,230	680	2,007	910
24"	508	2,641	760	2,492	1,130
26"	559	2,775	800	3,142	1,425
28"	610	2,825	800	3,418	1,550
30"	610	3,175	800	4,300	1,950
36"	711	3,600	800	6,725	3,050

ANSI Class 300

Size	Dimensions (mm)			Approx. Wt.	
	L	H	W	(lb.)	(kg.)
2"	216	424	200	53	24
2½"	241	460	250	96	44
3"	283	535	250	117	53
4"	305	615	250	168	76
5"	381	770	300	203	92
6"	403	795	350	322	146
8"	419	1,012	400	481	218
10"	457	1,231	450	776	352
12"	502	1,450	550	1,041	472
14"	762	1,645	600	1,530	694
16"	838	1,845	600	2,315	1,050
18"	914	1,995	680	2,977	1,350
20"	991	2,208	750	3,649	1,655
24"	1,143	2,650	800	5,182	2,350
30"	1,397	3,270	800	9,041	4,100

DPV Figure Numbers

Material	ANSI Class	
	150	300
A216 Gr. WCB	1512F	3012F
A352 Gr. LCC	151CF	301CF
A217 Gr. WC6	1516F	3016F
A217 Gr. WC9	1519F	3019F
A217 Gr. C5	1515F	3015F
A351 Gr. CF8	1514F	3014F
A351 Gr. CF3	1514LF	3014LF
A351 Gr. CF8M	1513F	3013F
A351 Gr. CF3M	1513LF	3013LF
A351 Gr. CN7M	1517F	3017F

DIMENSIONS

ANSI Class 600

Size	Dimensions (mm)			Approx. Wt.	
	L	H	W	(lb.)	(kg.)
2"	292	458	250	101	46
2½"	330	508	250	121	55
3"	356	570	250	159	72
4"	432	690	350	282	128
5"	508	880	400	397	180
6"	559	910	450	587	266
8"	660	1,064	500	924	419
10"	787	1,390	600	1,610	730
12"	838	1,650	680	1,874	850
14"	889	1,655	750	2,867	1,300
16"	991	1,905	750	3,859	1,750

ANSI Class 900

Size	Dimensions (mm)			Approx. Wt.	
	L	H	W	(lb.)	(kg.)
2"	368	445	300	187	85
3"	381	595	350	276	125
4"	457	750	400	397	180
6"	610	865	500	684	310
8"	737	1,225	600	1,158	525
10"	838	1,450	750	2,150	975
12"	965	1,675	800	3,197	1,450
14"	1,029	1,680	800	4,190	1,900
16"	1,130	1,925	800	5,634	2,555

ANSI Class 1500

Size	Dimensions (mm)			Approx. Wt.	
	L	H	W	(lb.)	(kg.)
2"	368	475	400	243	110
3"	470	600	400	320	145
4"	546	775	500	485	220
6"	705	925	600	889	403
8"	832	1,250	750	1,566	710
10"	991	1,525	800	2,977	1,350
12"	1,130	1,725	800	5,072	2,300
14"	1,257	1,750	800	6,836	3,100
16"	1,384	1,950	800	7,883	3,575

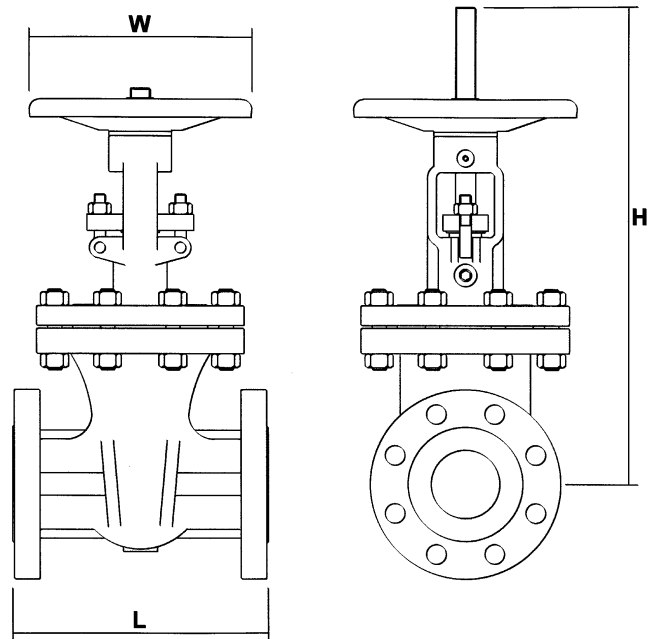

DPV Figure Numbers

Material	ANSI Class		
	600	900	1500
A216 Gr. WCB	6012F	9012F	15012F
A352 Gr. LCC	601CF	901CF	1501CF
A217 Gr. WC6	6016F	9016F	15016F
A217 Gr. WC9	6019F	9019F	15019F
A217 Gr. C5	6015F	9015F	15015F
A351 Gr. CF8	6014F	9014F	15014F
A351 Gr. CF3	6014LF	9014LF	15014LF
A351 Gr. CF8M	6013F	9013F	15013F
A351 Gr. CF3M	6013LF	9013LF	15013LF
A351 Gr. CN7M	6017F	9017F	15017F

GLOBE VALVE DESIGN FEATURES

- ◆ Swivel Plug Disc Design Standard
- ◆ Flat and Regulating Type Disc Available
- ◆ Bolted Bonnet Construction
- ◆ Outside Screw and Yoke, Rising Stem
- ◆ Manual Operated, Actuation Available
- ◆ Renewable Threaded-In Backseat Bushing
- ◆ Renewable Threaded-In or Welded-In Seat Ring
- ◆ Design : BS 1873 / API 600
- ◆ Shell Thickness : BS 1873 / API 600
- ◆ Flanged Ends : ANSI B16.5 (Sizes ≤ 24")
MSS SP-44 (Sizes > 24")
API 605 (Sizes > 24")
- ◆ Face-to-Face : ANSI B16.10
- ◆ Testing : API 598 / BS 6755 Part 1

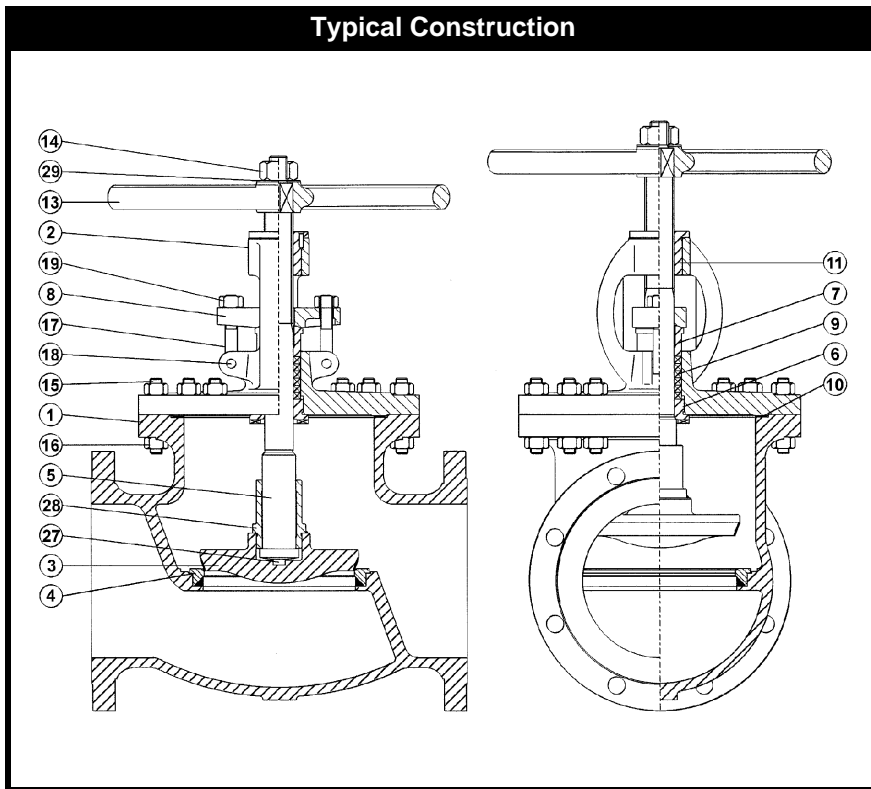

No.	Part Name
1	Body
2	Bonnet
3	Disc
4	Seat Ring
5	Stem
6	Backseat Bushing
7	Gland Bushing
8	Gland Flange
9	Packing
10	Gasket
11	Yoke Bushing
13	Handwheel
14	Handwheel Nut
15 / 16	Stud Bolt / Hex Nut
17	Eyebolt
18	Pin
19	Hex Nut
27 / 28	Disc Washer / Nut
29	Washer

Note: Weld end valves available upon request

- ◆ Heavy duty BODY with shell thickness to API / BS standards (where applicable)
- ◆ SEAT RING and WEDGE DISC ground and lapped to a mirror finish to provide matching sealing surfaces
- ◆ Plug Type DISC supplied as standard. Flat and Regulating Type DISC available upon request.
- ◆ Heat treated stainless steel STEM with precision machined ACME threads for long-lasting service
- ◆ Machined BACKSEAT BUSHING to provide a secondary metal-to-metal stem seal
- ◆ RISING STEM for open/close position indication
- ◆ Austenitic ductile iron YOKE SLEEVE to provide resistance to heat, corrosion and wear
- ◆ Two piece self-aligning GLAND BUSHING and GLAND FLANGE to prevent stem damage
- ◆ High strength alloy steel STUD BOLTS and heavy series HEX NUTS used
- ◆ Large diameter HANDWHEEL for easy operation
- ◆ Optional Deep Stuffing Box with Lantern Ring
- ◆ Angle and Y Body Patterns available

STANDARD MATERIALS OF CONSTRUCTION

Part	ANSI B16.34 Material Group				
	Carbon Steel	C-Mn Steel	Alloy Steel		
	1.1	1.2	1.9	1.10	1.13
Body / Bonnet	A216 Gr. WCB	A352 Gr. LCC	A217 Gr. WC6	A217 Gr. WC9	A217 Gr. C5
Gland Bushing	← 13% Chromium ASTM A182 Gr. F6a →				
Stud Bolts & Hex Nuts	B7 / 2H	L7 / 7	← ASTM A193 Gr. B16 / ASTM A194 Gr. 2H →		
Yoke / Gland Flange	← Carbon Steel →				
Yoke Bushing	← Austenitic Ductile Iron ASTM A439 Type D2 →				
Handwheel	← Ductile / Malleable Iron →				
Handwheel Nut	← Carbon Steel →				
Gland Eyebolts & Nuts	← Carbon Steel ASTM A307 Gr. B →				
Part	Corrosion Resistant Steel				
	2.1		2.2		3.17
	A351 Gr. CF8	A351 Gr. CF3	A351 Gr. CF8M	A351 Gr. CF3M	A351 Gr. CN7M
Body / Bonnet	A351 Gr. CF8	A351 Gr. CF3	A351 Gr. CF8M	A351 Gr. CF3M	A351 Gr. CN7M
Gland Bushing	304SS	304L SS	316SS	316L SS	Alloy 20
Stud Bolts & Hex Nuts	← Corrosion Resistant Steel ASTM A193 Gr. B8 / ASTM A194 Gr. 8 →				
Yoke / Gland Flange	← Corrosion Resistant Steel →				
Yoke Bushing	← Austenitic Ductile Iron ASTM A439 Type D2 →				
Handwheel	← Ductile / Malleable Iron →				
Handwheel Nut	← Carbon Steel →				
Gland Eyebolts & Nuts	← Corrosion Resistant Steel ASTM A193 Gr. B8 / ASTM A194 Gr. 8 →				

Note: Other materials available upon request.

Trim Materials

Part	API Trim No.										
	1	2	5	8	9	10	11	12	13	14	15
Disc	F6	304SS	HF	F6	Ni-Cu	316SS	Ni-Cu	316SS	Alloy 20	Alloy 20	HF
Seat Ring	F6	304SS	HF	HF	Ni-Cu	316SS	HF	HF	Alloy 20	HF	HF
Stem	F6	304SS	F6	F6	Ni-Cu	316SS	Ni-Cu	316SS	Alloy 20	Alloy 20	304SS
Backseat	F6	304SS	F6	F6	Ni-Cu	316SS	Ni-Cu	316SS	Alloy 20	Alloy 20	304SS
Washer / Nut	F6	304SS	F6	F6	Ni-Cu	316SS	Ni-Cu	316SS	Alloy 20	Alloy 20	304SS
Part	API Trim No.			DPV Trim No.							
	16	17	18	A	B	C	D	E	F	G	H
Disc	HF	HF	HF	HF	Bronze	F6	304SS	316SS	Ni-Cu	Alloy 20	Bronze
Seat Ring	HF	HF	HF	HF	Bronze	PTFE	PTFE	PTFE	PTFE	PTFE	PTFE
Stem	316SS	347SS	Alloy 20	Ni-Cu	Brass	F6	304SS	316SS	Ni-Cu	Alloy 20	Brass
Backseat	316SS	347SS	Alloy 20	Ni-Cu	Brass	F6	304SS	316SS	Ni-Cu	Alloy 20	Brass
Washer / Nut	316SS	347SS	Alloy 20	Ni-Cu	Brass	F6	304SS	316SS	Ni-Cu	Alloy 20	Brass

Note: Trim will be supplied either as a base material equal to body with overlay or solid trim at manufacturer's option.

DIMENSIONS

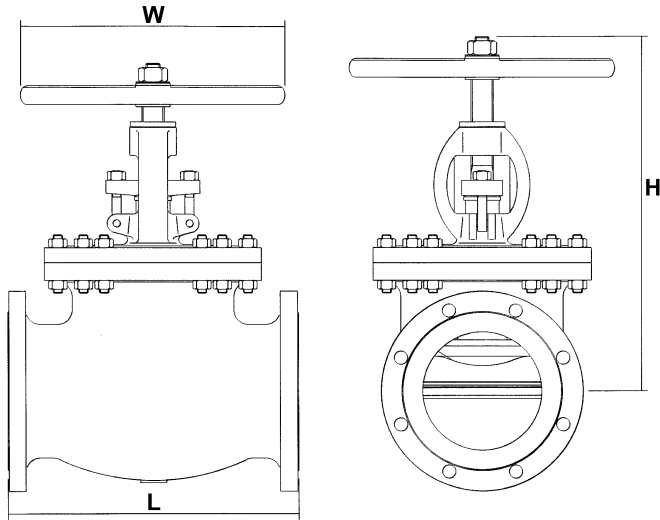

ANSI Class 150

Size	Dimensions (mm)			Approx. Wt.	
	L	H	W	(lb.)	(kg.)
2"	203	350	200	49	22
2½"	216	403	250	66	30
3"	241	405	250	93	42
4"	292	478	350	132	60
5"	356	513	350	170	77
6"	406	555	350	214	97
8"	495	610	450	355	161
10"	622	730	500	679	308
12"	699	1,008	600	904	410
14"	787	1,200	600	1,191	540
16"	914	1,270	650	1,676	760
18"	978	1,300	650	2,315	1,050
20"	978	1,350	700	2,701	1,225
24"	1,295	1,450	750	3,638	1,650

ANSI Class 300

Size	Dimensions (mm)			Approx. Wt.	
	L	H	W	(lb.)	(kg.)
2"	267	420	200	61	28
2½"	292	435	250	110	50
3"	318	450	250	126	57
4"	356	520	350	182	83
5"	400	620	400	298	135
6"	445	650	450	331	150
8"	559	800	500	875	397
10"	622	1,040	500	1,162	527
12"	711	1,140	600	1,341	608
14"	838	1,250	700	1,687	765
16"	864	1,295	750	2,426	1,100
18"	978	1,340	800	3,241	1,470
20"	1,016	1,385	915	3,704	1,680
24"	1,346	1,475	915	5,457	2,475

DPV Figure Numbers

Material	ANSI Class	
	150	300
A216 Gr. WCB	1522F	3022F
A352 Gr. LCC	152CF	302CF
A217 Gr. WC6	1526F	3026F
A217 Gr. WC9	1529F	3029F
A217 Gr. C5	1525F	3025F
A351 Gr. CF8	1524F	3024F
A351 Gr. CF3	1524LF	3024LF
A351 Gr. CF8M	1523F	3023F
A351 Gr. CF3M	1523LF	3023LF
A351 Gr. CN7M	1527F	3027F

DIMENSIONS

ANSI Class 600

Size	Dimensions (mm)			Approx. Wt.	
	L	H	W	(lb.)	(kg.)
2"	292	457	250	95	43
2½"	330	470	300	161	73
3"	356	584	350	196	89
4"	432	660	450	329	149
5"	508	820	500	463	210
6"	559	850	550	919	417
8"	660	1,050	600	1,195	542
10"	787	1,140	600	1,526	692
12"	838	1,320	750	2,150	975
14"	889	1,350	800	2,459	1,115
16"	991	1,550	800	3,263	1,480

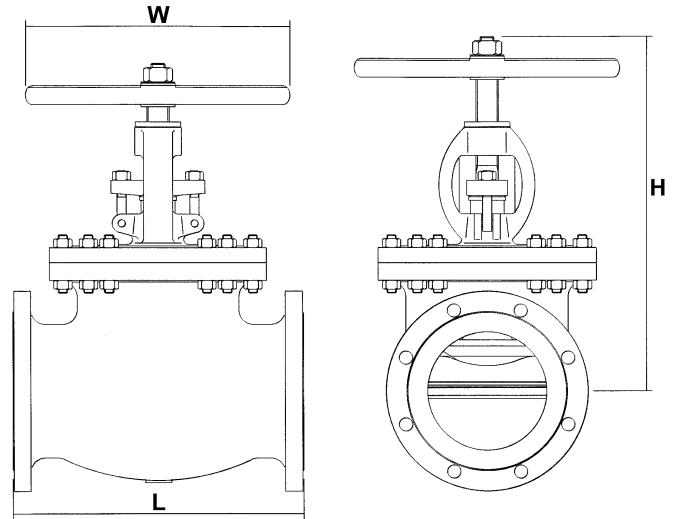

ANSI Class 900

Size	Dimensions (mm)			Approx. Wt.	
	L	H	W	(lb.)	(kg.)
2"	368	495	300	212	96
2½"	419	540	350	174	79
3"	381	600	350	258	117
4"	457	655	500	392	178
5"	559	670	500	673	305
6"	610	780	600	783	355
8"	737	1,050	600	1,610	730
10"	838	1,300	750	2,315	1,050
12"	965	1,480	800	2,977	1,350

ANSI Class 1500

Size	Dimensions (mm)			Approx. Wt.	
	L	H	W	(lb.)	(kg.)
2"	368	550	300	256	116
2½"	419	580	350	276	125
3"	470	625	400	320	145
4"	546	750	450	463	210
5"	673	810	500	871	395
6"	705	925	600	1,047	475
8"	832	1,225	600	2,040	925
10"	991	1,450	750	3,010	1,365
12"	1,130	1,870	800	4,851	2,200

DPV Figure Numbers

Material	ANSI Class		
	600	900	1500
A216 Gr. WCB	6022F	9022F	15022F
A352 Gr. LCC	602CF	902CF	1502CF
A217 Gr. WC6	6026F	9026F	15026F
A217 Gr. WC9	6029F	9029F	15029F
A217 Gr. C5	6025F	9025F	15025F
A351 Gr. CF8	6024F	9024F	15024F
A351 Gr. CF3	6024LF	9024LF	15024LF
A351 Gr. CF8M	6023F	9023F	15023F
A351 Gr. CF3M	6023LF	9023LF	15023LF
A351 Gr. CN7M	6027F	9027F	15027F

SWING CHECK VALVE DESIGN FEATURES

- ◆ Swing Disc Design
- ◆ Regular Opening Type
- ◆ Bolted Cover Construction
- ◆ Internal Hinge Design Standard
- ◆ Through-Body Hinge Pin Design Available
- ◆ Renewable Threaded-In or Welded-In Seat Ring

- ◆ Design : API 6D / API 600 / BS 1868
- ◆ Shell Thickness : API 6D / API 600 / BS 1868
- ◆ Flanged Ends : ANSI B16.5 (Sizes ≤ 24")
MSS SP-44 (Sizes > 24")
API 605 (Sizes > 24")
- ◆ Face-to-Face : ANSI B16.10
- ◆ Testing : API 598 / BS 6755 Part 1

Typical Construction

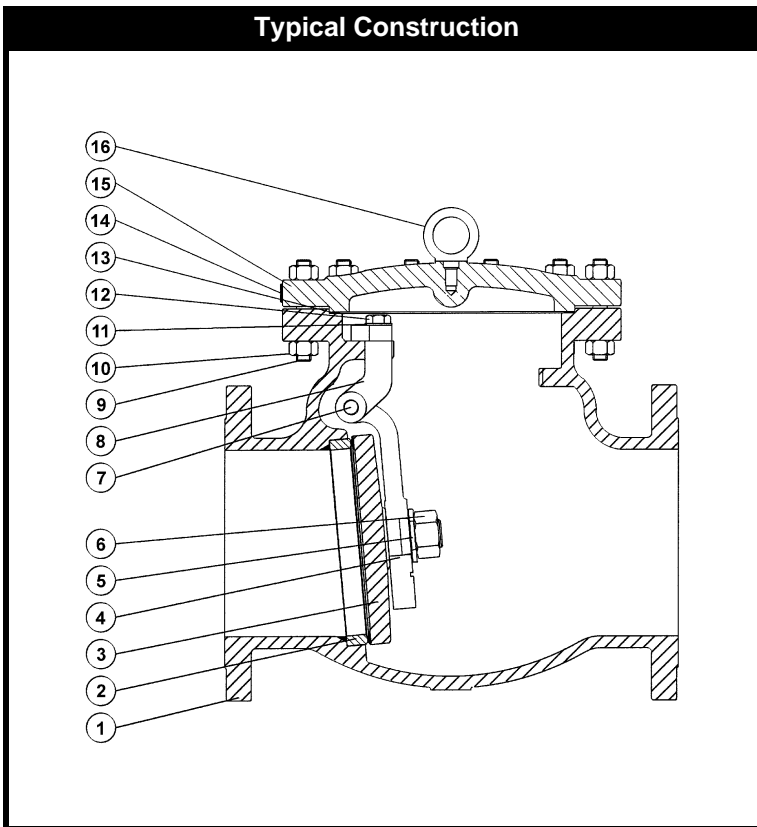

No.	Part Name
1	Body
2	Seat Ring
3	Disc
4	Hinge
5	Disc Washer
6	Disc Nut
7	Hinge Pin
8	Bracket
9	Stud Bolt
10	Hex Nut
11	Washer
13	Capscrew
14	Nameplate
15	Cover
16	Lifting Lug

Note: Weld end valves available upon request

- ◆ Heavy duty BODY with shell thickness to API / BS standards (where applicable)
- ◆ SEAT RING and DISC ground and lapped to a mirror finish to provide matching sealing surfaces
- ◆ Free rotating DISC design to minimize localized wear on sealing surface
- ◆ Y Body Pattern available

- ◆ Standard internal HINGE design eliminates body penetration and allows ease of maintenance since all parts are accessible from the top and the valve can be serviced insitu
- ◆ Through-body HINGE PIN design available for outside lever, counter weight or slam retarder
- ◆ High strength alloy steel STUD BOLTS and heavy series HEX NUTS used

SWING CHECK VALVES



STANDARD MATERIALS OF CONSTRUCTION

Part	ANSI B16.34 Material Group				
	Carbon Steel	C-Mn Steel	Alloy Steel		
	1.1	1.2	1.9	1.10	1.13
Body / Cover	A216 Gr. WCB	A352 Gr. LCC	A217 Gr. WC6	A217 Gr. WC9	A217 Gr. C5
Hinge / Bracket	A216 Gr. WCB	A352 Gr. LCC	A217 Gr. WC6	A217 Gr. WC9	A217 Gr. C5
Stud Bolts	A193 Gr. B7	A320 Gr. L7	← Alloy Steel ASTM A193 Gr. B16 →		
Hex Nuts	A194 Gr. 2H	A194 Gr. 7	← Carbon Steel ASTM A194 Gr. 2H →		
Washer / Capscrew	← Carbon Steel →		← Alloy Steel →		
Part	Corrosion Resistant Steel				
	2.1		2.2		3.17
	A351 Gr. CF8	A351 Gr. CF3	A351 Gr. CF8M	A351 Gr. CF3M	A351 Gr. CN7M
Body / Cover	A351 Gr. CF8	A351 Gr. CF3	A351 Gr. CF8M	A351 Gr. CF3M	A351 Gr. CN7M
Hinge / Bracket	A351 Gr. CF8	A351 Gr. CF3	A351 Gr. CF8M	A351 Gr. CF3M	A351 Gr. CN7M
Stud Bolts	← ASTM A193 Gr. B8 →		← ASTM A193 Gr. B8M →		
Hex Nuts	← ASTM A194 Gr. 8 →		← ASTM A194 Gr. 8M →		
Washer / Capscrew	← Corrosion Resistant Steel →				

Note: Other materials available upon request.

Trim Materials

Part	API Trim No.										
	1	2	5	8	9	10	11	12	13	14	15
Disc	F6	304SS	HF	F6	Ni-Cu	316SS	Ni-Cu	316SS	Alloy 20	Alloy 20	HF
Seat Ring	F6	304SS	HF	HF	Ni-Cu	316SS	HF	HF	Alloy 20	HF	HF
Disc Washer	F6	304SS	F6	F6	Ni-Cu	316SS	Ni-Cu	316SS	Alloy 20	Alloy 20	304SS
Disc Nut	F6	304SS	F6	F6	Ni-Cu	316SS	Ni-Cu	316SS	Alloy 20	Alloy 20	304SS
Hinge Pin	F6	304SS	F6	F6	Ni-Cu	316SS	Ni-Cu	316SS	Alloy 20	Alloy 20	304SS
Part	API Trim No.					DPV Trim No.					
	16	17	18	A	B	C	D	E	F	G	H
Disc	HF	HF	HF	HF	Bronze	F6	304SS	316SS	Ni-Cu	Alloy 20	Bronze
Seat Ring	HF	HF	HF	HF	Bronze	PTFE	PTFE	PTFE	PTFE	PTFE	PTFE
Disc Washer	316SS	347SS	Alloy 20	Ni-Cu	Bronze	F6	304SS	316SS	Ni-Cu	Alloy 20	Bronze
Disc Nut	316SS	347SS	Alloy 20	Ni-Cu	Bronze	F6	304SS	316SS	Ni-Cu	Alloy 20	Bronze
Hinge Pin	316SS	347SS	Alloy 20	Ni-Cu	Bronze	F6	304SS	316SS	Ni-Cu	Alloy 20	Bronze

Note: Trim will be supplied either as a base material equal to body with overlay or solid trim at manufacturer's option.

Gasket Materials

Type	ANSI Class				
	150	300	600	900	1500
S.S. Spiral Wound	●	●	○	○	○
Soft Iron Ring	N/A	N/A	●	●	●

● Standard ○ Optional Other types available upon request.

DIMENSIONS

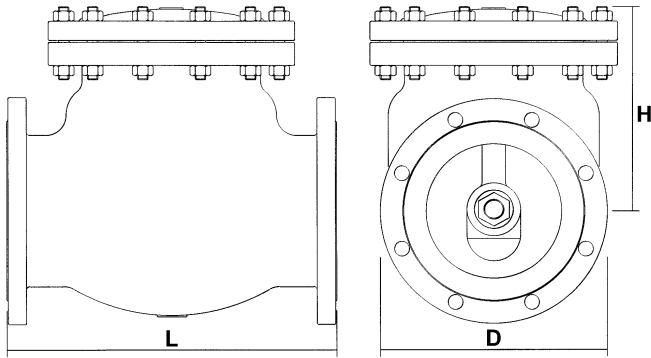

ANSI Class 150

Size	Dimensions (mm)			Approx. Wt.	
	L	H	D	(lb.)	(kg.)
2"	203	156	152	42	19
2½"	216	170	178	57	26
3"	241	180	191	62	28
4"	292	213	229	105	48
5"	330	229	254	152	69
6"	356	307	279	172	78
8"	495	357	343	293	133
10"	622	390	406	587	266
12"	699	410	483	765	347
14"	787	415	533	994	451
16"	864	460	597	1,226	556
18"	978	570	635	1,738	788
20"	978	625	699	2,020	916
24"	1,295	675	813	2,811	1,275

ANSI Class 300

Size	Dimensions (mm)			Approx. Wt.	
	L	H	D	(lb.)	(kg.)
2"	267	198	165	46	21
2½"	292	203	191	66	30
3"	318	222	210	94	43
4"	356	266	254	146	66
5"	400	292	279	185	84
6"	445	326	318	276	125
8"	533	400	381	430	195
10"	622	455	445	666	302
12"	711	543	521	858	389
14"	838	500	584	1,433	650
16"	864	545	648	1,764	800
18"	978	605	711	2,139	970
20"	1,016	675	775	2,977	1,350
24"	1,346	785	914	4,873	2,210

DPV Figure Numbers

Material	ANSI Class	
	150	300
A216 Gr. WCB	1532F	3032F
A352 Gr. LCC	153CF	303CF
A217 Gr. WC6	1536F	3036F
A217 Gr. WC9	1539F	3039F
A217 Gr. C5	1535F	3035F
A351 Gr. CF8	1534F	3034F
A351 Gr. CF3	1534LF	3034LF
A351 Gr. CF8M	1533F	3033F
A351 Gr. CF3M	1533LF	3033LF
A351 Gr. CN7M	1537F	3037F

SWING CHECK VALVES



DIMENSIONS

ANSI Class 600

Size	Dimensions (mm)			Approx. Wt.	
	L	H	D	(lb.)	(kg.)
2"	292	224	165	76	34
2½"	330	245	191	139	63
3"	356	278	210	165	75
4"	432	307	273	212	96
5"	508	498	330	355	161
6"	559	394	356	501	227
8"	660	468	419	763	346
10"	787	554	508	1,202	545
12"	838	575	559	1,720	780
14"	889	580	603	1,929	875
16"	991	630	686	2,370	1,075

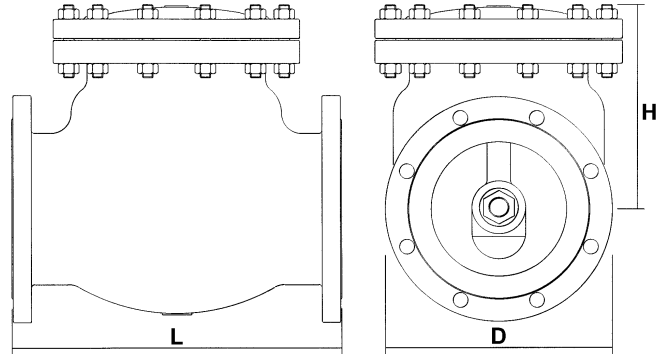

ANSI Class 900

Size	Dimensions (mm)			Approx. Wt.	
	L	H	D	(lb.)	(kg.)
2"	368	195	216	121	55
2½"	419	235	244	154	70
3"	381	260	241	198	90
4"	457	275	292	298	135
5"	559	320	349	364	165
6"	610	370	381	650	295
8"	737	435	470	1,158	525
10"	838	520	546	1,985	900
12"	965	530	610	2,370	1,075

ANSI Class 1500

Size	Dimensions (mm)			Approx. Wt.	
	L	H	D	(lb.)	(kg.)
2"	368	220	216	154	70
2½"	419	270	244	187	85
3"	470	290	267	254	115
4"	546	310	311	386	175
5"	673	350	375	397	180
6"	705	410	394	816	370
8"	832	485	483	1,499	680
10"	991	737	584	3,711	1,683
12"	1,130	875	673	5,281	2,395

DPV Figure Numbers

Material	ANSI Class		
	600	900	1500
A216 Gr. WCB	6032F	9032F	15032F
A352 Gr. LCC	603CF	903CF	1503CF
A217 Gr. WC6	6036F	9036F	15036F
A217 Gr. WC9	6039F	9039F	15039F
A217 Gr. C5	6035F	9035F	15035F
A351 Gr. CF8	6034F	9034F	15034F
A351 Gr. CF3	6034LF	9034LF	15034LF
A351 Gr. CF8M	6033F	9033F	15033F
A351 Gr. CF3M	6033LF	9033LF	15033LF
A351 Gr. CN7M	6037F	9037F	15037F

BEVEL GEAR OPERATOR

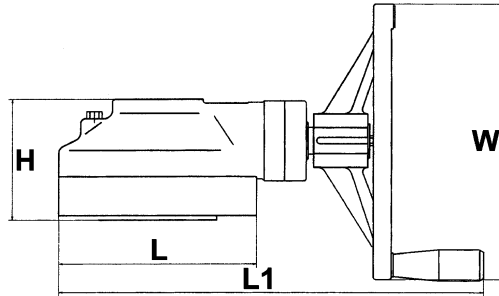

Model No.	Torque		Thrust		Ratio	L mm	L1 mm	H mm	W mm	Weight		Model No.
	ft-lbf	NM	lbf	kN						lb	kg	
BG-0	540	735	22,030	98	3:1	218	467	140	308	53	24	BG-0
BG-1	1,100	1,500	44,060	196	4.1:1	289	555	160	460	93	42	BG-1
BG-2	2,210	3,000	78,680	350	6:1	385	694	230	610	192	87	BG-2
BG-3	4,420	6,000	141,630	630	19.3:1	510	877	270	610	340	154	BG-3

Bevel Gear Operator Sizing

Valve Size	Gate Valve					Globe Valve					Valve Size
	ANSI Class					ANSI Class					
	150	300	600	900	1500	150	300	600	900	1500	
2"	BG-0	BG-0	BG-0	BG-0	BG-0	BG-0	BG-0	BG-0	BG-0	BG-0	2"
2½"	BG-0	BG-0	BG-0	BG-0	BG-0	BG-0	BG-0	BG-0	BG-0	BG-0	2½"
3"	BG-0	BG-0	BG-0	BG-0	BG-0	BG-0	BG-0	BG-0	BG-0	BG-1	3"
4"	BG-0	BG-0	BG-0	BG-0	BG-0	BG-0	BG-0	BG-0	BG-1	BG-2	4"
5"	BG-0	BG-0	BG-0	BG-0	BG-1	BG-0	BG-0	BG-1	BG-2	BG-3	5"
6"	BG-0	BG-0	BG-0	BG-0	BG-1	BG-0	BG-1	BG-2	BG-2	BG-3	6"
8"	BG-0	BG-0	BG-1	BG-1	BG-2	BG-0	BG-1	BG-3	BG-3	-	8"
10"	BG-0	BG-0	BG-1	BG-2	BG-3	BG-1	BG-2	BG-3	-	-	10"
12"	BG-0	BG-1	BG-2	BG-2	BG-3	BG-1	BG-3	-	-	-	12"
14"	BG-0	BG-1	BG-2	BG-3	-	BG-2	BG-3	-	-	-	14"
16"	BG-1	BG-1	BG-2	BG-3	-	BG-2	-	-	-	-	16"
18"	BG-1	BG-2	BG-3	-	-	BG-3	-	-	-	-	18"
20"	BG-1	BG-2	BG-3	-	-	BG-3	-	-	-	-	20"
24"	BG-2	BG-3	-	-	-	-	-	-	-	-	24"
26"	BG-2	BG-3	-	-	-	-	-	-	-	-	26"
28"	BG-2	BG-3	-	-	-	-	-	-	-	-	28"
30"	BG-3	BG-3	-	-	-	-	-	-	-	-	30"
36"	BG-3	-	-	-	-	-	-	-	-	-	36"

Note: **BOLD & ITALIC** means bevel gear operator recommended.

OPTIONAL MODIFICATIONS

SPECIAL SERVICES

- ◆ Extended Stem / Handwheel Elevations
- ◆ Extended Bonnet / Elevated Stuffing Box
- ◆ Floorstands / Universal Joints
- ◆ Soft Seal Inserts on Disc or Seat(s)
- ◆ Lantern Ring / Leak-Out Port
- ◆ Live-Loaded Packing
- ◆ Oxygen / Chlorine Service
- ◆ Double Block & Bleed Operation
- ◆ Quick Closing / Opening Operation
- ◆ Fail Closed / Fail Open Operation
- ◆ Outside Lever & Weight for Check Valves
- ◆ Slam Retarder for Check Valves
- ◆ Bypass Piping (see below)

NON-DESTRUCTIVE TESTING

- ◆ Radiographic Examination
- ◆ Magnetic Particle Examination
- ◆ Dye Penetrant Examination

OPERATION

- ◆ Hammer-Blow / Impactor Handwheels
- ◆ Bevel Gear / Chainwheel Operator
- ◆ Multi-Turn Electric Actuator
- ◆ Linear Pneumatic Actuator
- ◆ Linear Hydraulic Actuator
- ◆ Linear Electro-Hydraulic Actuator

Chainwheel Operator	
No.	Suitable for Valve Handwheel Ø
0	2" to 4"
1	4¼" to 5¾"
1½	6" to 7½"
2	7¾" to 9"
2½	9¼" to 12½"
3	12¾" to 15½"
3½	15¾" to 19"
4	19¼" to 22"
4½	22¼" to 26"
5	26¼" to 36"

AUXILIARY CONNECTIONS

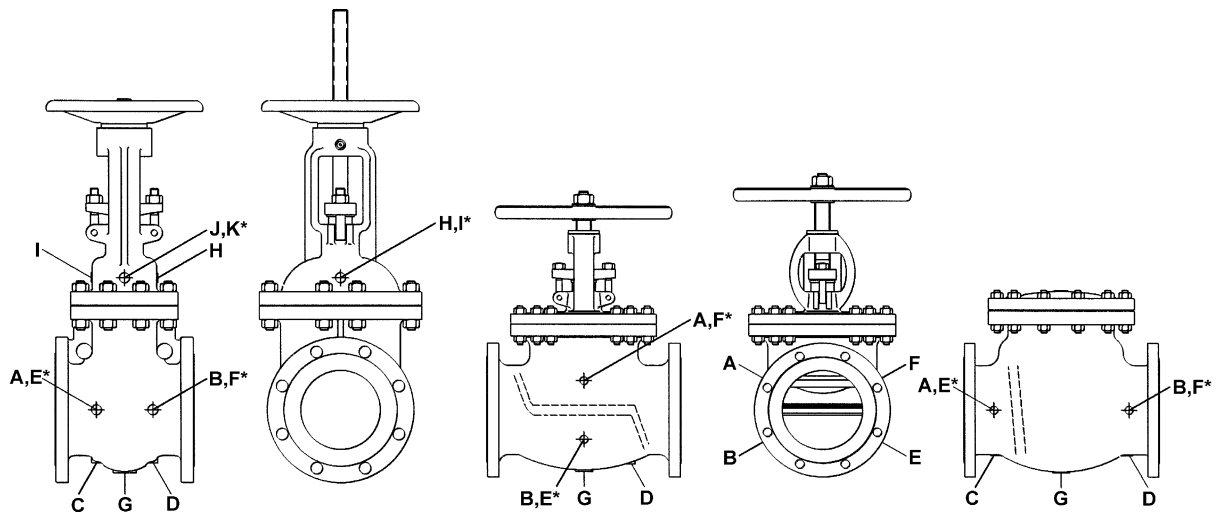

Nominal Valve Size	2" to 4"	5" to 8"	10" to 12"	14" and Larger
Connection Size	½"	¾"	1"	1½"

* Same location on the other side.

END FLANGE DIMENSIONS (in.)

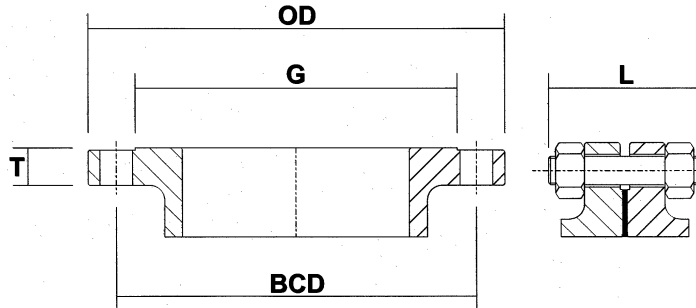

ANSI / ASME B16.5 Class 150 R.F. (1/16" Raised Face)

Size	OD	T		G	BCD	Bolt Hole Ø	No. of Bolt Holes	Stud Bolt Ø	L	Size
	Outside Ø	Companion Flange	Valve Flange	R.F. Ø	Bolt Circle Ø				Bolt Length	
2	6	3/4	5/8	3 5/8	4 3/4	3/4	4	5/8	3	2
2½	7	7/8	11/16	4 1/8	5 1/2	3/4	4	5/8	3 1/4	2½
3	7 1/2	15/16	15/16	5	6	3/4	4	5/8	3 3/4	3
4	9	15/16	15/16	6 3/16	7 1/2	3/4	8	5/8	3 3/4	4
5	10	15/16	15/16	7 5/16	8 1/2	7/8	8	3/4	4	5
6	11	1	1	8 1/2	9 1/2	7/8	8	3/4	4	6
8	13 1/2	1 1/8	1 1/8	10 5/8	12	7/8	8	3/4	4 1/4	8
10	16	1 3/16	1 3/16	12 3/4	14 1/4	1	12	7/8	4 3/4	10
12	19	1 1/4	1 1/4	15	17	1	12	7/8	4 3/4	12
14	21	1 3/8	1 3/8	16 1/4	18 3/4	1 1/8	12	1	5 1/4	14
16	23 1/2	1 7/16	1 7/16	18 1/2	21 1/4	1 1/8	16	1	5 1/2	16
18	25	1 9/16	1 9/16	21	22 3/4	1 1/4	16	1 1/8	6	18
20	27 1/2	1 11/16	1 11/16	23	25	1 1/4	20	1 1/8	6 1/4	20
24	32	1 7/8	1 7/8	27 1/4	29 1/2	1 3/8	20	1 1/4	6 3/4	24

MSS SP-44 / ASME B16.47 Series A Class 150 R.F. (1/16" Raised Face)

22	29 1/2	1 13/16	1 13/16	25 1/4	27 1/4	1 3/8	20	1 1/4	6 3/4	22
26	34 1/4	2 11/16	2 11/16	29 1/2	31 3/4	1 3/8	24	1 1/4	8 1/2	26
28	36 1/2	2 13/16	2 13/16	31 1/2	34	1 3/8	28	1 1/4	8 3/4	28
30	38 3/4	2 15/16	2 15/16	33 3/4	36	1 3/8	28	1 1/4	9	30
36	46	3 9/16	3 9/16	40 1/4	42 3/4	1 5/8	32	1 1/2	10 3/4	36

API 605 / ASME B16.47 Series B Class 150 R.F. (1/16" Raised Face)

26	30 15/16	1 5/8	1 5/8	28	29 5/16	7/8	36	3/4	5 1/2	26
28	32 15/16	1 3/4	1 3/4	30	31 5/16	7/8	40	3/4	5 3/4	28
30	34 15/16	1 3/4	1 3/4	32	33 5/16	7/8	44	3/4	5 3/4	30
36	41 5/8	2 1/16	2 1/16	38 1/4	39 3/4	1	44	7/8	6 1/2	36

END FLANGE DIMENSIONS (in.)

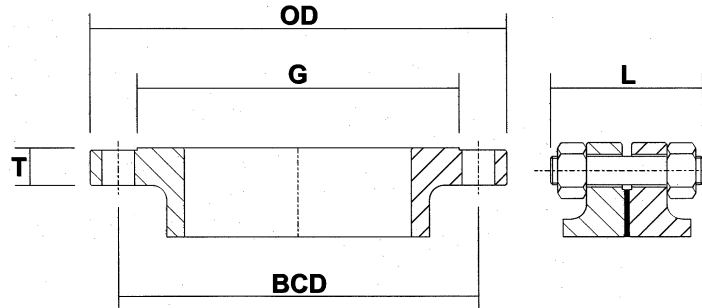

ANSI / ASME B16.5 Class 300 R.F. (1/16" Raised Face)									
Size	OD	T	G	BCD	Bolt Hole Ø	No. of Bolt Holes	Stud Bolt Ø	L	Size
	Outside Ø	Flange Thickness	R.F. Ø	Bolt Circle Ø				Bolt Length	
2	6 1/2	7/8	3 5/8	5	3/4	8	5/8	3 1/2	2
2½	7 1/2	1	4 1/8	5 7/8	7/8	8	3/4	4	2½
3	8 1/4	1 1/8	5	6 5/8	7/8	8	3/4	4 1/4	3
4	10	1 1/4	6 3/16	7 7/8	7/8	8	3/4	4 1/2	4
5	11	1 3/8	7 5/16	9 1/4	7/8	8	3/4	4 3/4	5
6	12 1/2	1 7/16	8 1/2	10 5/8	7/8	12	3/4	4 3/4	6
8	15	1 5/8	10 5/8	13	1	12	7/8	5 1/2	8
10	17 1/2	1 7/8	12 3/4	15 1/4	1 1/8	16	1	6 1/4	10
12	20 1/2	2	15	17 3/4	1 1/4	16	1 1/8	6 3/4	12
14	23	2 1/8	16 1/4	20 1/4	1 1/4	20	1 1/8	7	14
16	25 1/2	2 1/4	18 1/2	22 1/2	1 3/8	20	1 1/4	7 1/2	16
18	28	2 3/8	21	24 3/4	1 3/8	24	1 1/4	7 3/4	18
20	30 1/2	2 1/2	23	27	1 3/8	24	1 1/4	8	20
24	36	2 3/4	27 1/4	32	1 5/8	24	1 1/2	9	24
MSS SP-44 / ASME B16.47 Series A Class 300 R.F. (1/16" Raised Face)									
22	33	2 5/8	25 1/4	29 1/4	1 5/8	24	1 1/2	9	22
26	38 1/4	3 1/8	29 1/2	34 1/2	1 3/4	28	1 5/8	10 1/4	26
28	40 3/4	3 3/8	31 1/2	37	1 3/4	28	1 5/8	10 3/4	28
30	43	3 5/8	33 3/4	39 1/4	1 7/8	28	1 3/4	11 1/2	30
36	50	4 1/8	40 1/4	46	2 1/8	32	2	13	36
API 605 / ASME B16.47 Series B Class 300 R.F. (1/16" Raised Face)									
26	34 1/8	3 1/2	29	31 5/8	1 3/8	32	1 1/4	10 1/4	26
28	36 1/4	3 1/2	31	33 3/4	1 3/8	36	1 1/4	10 1/4	28
30	39	3 11/16	33 1/4	36 1/4	1 1/2	36	1 3/8	10 3/4	30
36	46 1/8	4 1/16	39 3/4	42 7/8	1 3/4	32	1 5/8	12	36

END FLANGE DIMENSIONS (in.)

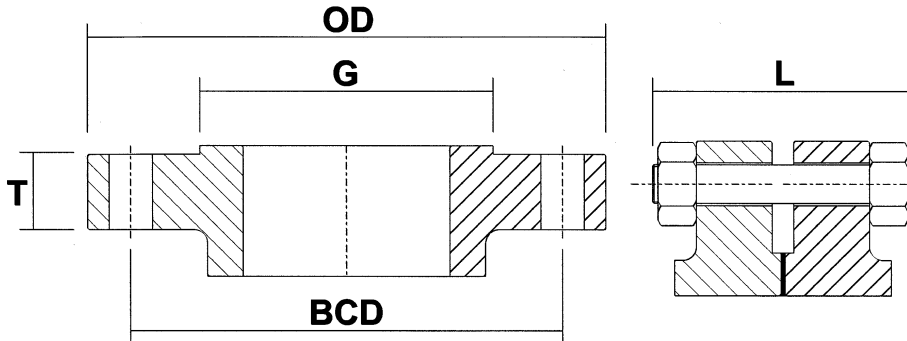

ANSI / ASME B16.5 Class 600 R.F. (1/4" Raised Face)

Size	OD	T	G	BCD	Bolt Hole Ø	No. of Bolt Holes	Stud Bolt Ø	L	Size
	Outside Ø	Flange Thickness	R.F. Ø	Bolt Circle Ø				Bolt Length	
2	6 1/2	1	3 5/8	5	3/4	8	5/8	4 1/4	2
2½	7 1/2	1 1/8	4 1/8	5 7/8	7/8	8	3/4	4 3/4	2½
3	8 1/4	1 1/4	5	6 5/8	7/8	8	3/4	5	3
4	10 3/4	1 1/2	6 3/16	8 1/2	1	8	7/8	5 3/4	4
5	13	1 3/4	7 5/16	10 1/2	1 1/8	8	1	6 1/2	5
6	14	1 7/8	8 1/2	11 1/2	1 1/8	12	1	6 3/4	6
8	16 1/2	2 3/16	10 5/8	13 3/4	1 1/4	12	1 1/8	7 1/2	8
10	20	2 1/2	12 3/4	17	1 3/8	16	1 1/4	8 1/2	10
12	22	2 5/8	15	19 1/4	1 3/8	20	1 1/4	8 3/4	12
14	23 3/4	2 3/4	16 1/4	20 3/4	1 1/2	20	1 3/8	9 1/4	14
16	27	3	18 1/2	23 3/4	1 5/8	20	1 1/2	10	16
18	29 1/4	3 1/4	21	25 3/4	1 3/4	20	1 5/8	10 3/4	18
20	32	3 1/2	23	28 1/2	1 3/4	24	1 5/8	11 1/4	20
24	37	4	27 1/4	33	2	24	1 7/8	13	24

MSS SP-44 / ASME B16.47 Series A Class 600 R.F. (1/4" Raised Face)

26	40	4 1/4	29 1/2	36	2	28	1 7/8	9 3/4	26
28	42 1/4	4 3/8	31 1/2	38	2 1/8	28	2	10	28
30	44 1/2	4 1/2	33 3/4	40 1/4	2 1/8	28	2	10 1/4	30
32	47	4 5/8	36	42 1/2	2 3/8	28	2 1/4	10 1/2	32
36	51 3/4	4 7/8	40 1/4	47	2 5/8	28	2 1/2	11	36

API 605 / ASME B16.47 Series B Class 600 R.F. (1/4" Raised Face)

26	35	4 3/8	28 5/8	31 3/4	1 3/4	28	1 5/8	13 1/4	26
28	37 1/2	4 9/16	30 7/8	34	1 7/8	28	1 3/4	13 3/4	28
30	40 1/4	4 15/16	33 1/8	36 1/2	2	28	1 7/8	14 3/4	30
36	47 3/4	5 49/64	39 3/4	43 1/2	2 3/8	28	2 1/4	17 1/4	36

END FLANGE DIMENSIONS (in.)

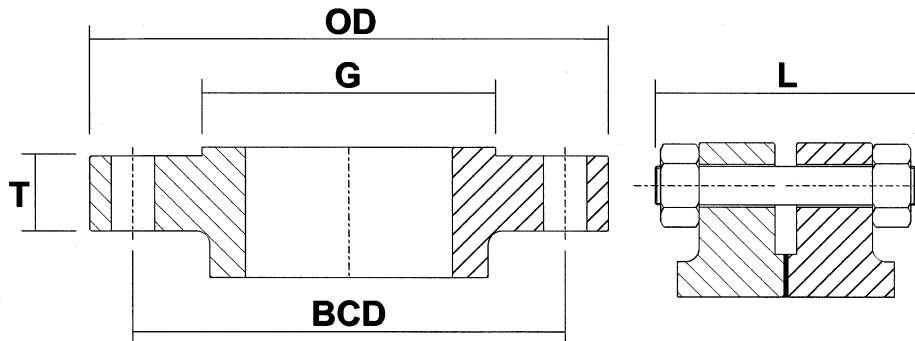

ANSI / ASME B16.5 Class 900 R.F. (1/4" Raised Face)

Size	OD	T	G	BCD	Bolt Hole Ø	No. of Bolt Holes	Stud Bolt Ø	L	Size
	Outside Ø	Flange Thickness	R.F. Ø	Bolt Circle Ø				Bolt Length	
2	8 1/2	1 1/2	3 5/8	6 1/2	1	8	7/8	5 3/4	2
2½	9 5/8	1 5/8	4 1/8	7 1/2	1 1/8	8	1	6 1/4	2½
3	9 1/2	1 1/2	5	7 1/2	1	8	7/8	5 3/4	3
4	11 1/2	1 3/4	6 3/16	9 1/4	1 1/4	8	1 1/8	6 3/4	4
5	13 3/4	2	7 5/16	11	1 3/8	8	1 1/4	7 1/2	5
6	15	2 3/16	8 1/2	12 1/2	1 1/4	12	1 1/8	7 1/2	6
8	18 1/2	2 1/2	10 5/8	15 1/2	1 1/2	12	1 3/8	8 3/4	8
10	21 1/2	2 3/4	12 3/4	18 1/2	1 1/2	16	1 3/8	9 1/4	10
12	24	3 1/8	15	21	1 1/2	20	1 3/8	10	12
14	25 1/4	3 3/8	16 1/4	22	1 5/8	20	1 1/2	10 3/4	14
16	27 3/4	3 1/2	18 1/2	24 1/4	1 3/4	20	1 5/8	11 1/4	16
18	31	4	21	27	2	20	1 7/8	12 3/4	18
20	33 3/4	4 1/4	23	29 1/2	2 1/8	20	2	13 3/4	20
24	41	5 1/2	27 1/4	35 1/2	2 5/8	20	2 1/2	17 1/4	24

MSS SP-44 / ASME B16.47 Series A Class 900 R.F. (1/4" Raised Face)

26	42 3/4	5 1/2	29 1/2	37 1/2	2 7/8	20	2 3/4	17 3/4	26
28	46	5 5/8	31 1/2	40 1/4	3 1/8	20	3	18 1/2	28
30	48 1/2	5 7/8	33 3/4	42 3/4	3 1/8	20	3	19	30
32	51 3/4	6 1/4	36	45 1/2	3 3/8	20	3 1/4	20 1/4	32
36	57 1/2	6 1/2	40 1/4	50 3/4	3 5/8	20	3 1/2	21 1/4	36

API 605 / ASME B16.47 Series B Class 900 R.F. (1/4" Raised Face)

26	40 1/4	5 5/16	30	35 1/2	2 5/8	20	2 1/2	16 3/4	26
28	43 1/2	5 13/16	32 1/4	38 1/4	2 7/8	20	2 3/4	18 1/4	28
30	46 1/2	6 1/8	34 1/2	40 3/4	3 1/8	20	3	19 1/2	30
36	53	6 13/16	40 1/2	47 1/4	3 1/8	24	3	20 3/4	36

END FLANGE DIMENSIONS (in.)

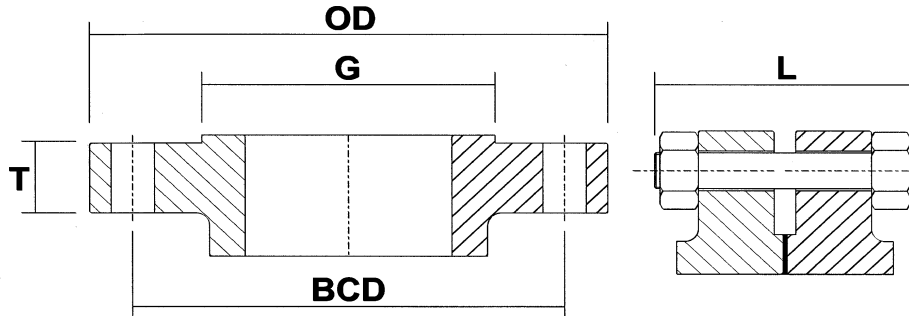

ANSI / ASME B16.5 Class 1500 R.F. (1/4" Raised Face)

Size	OD	T	G	BCD	Bolt Hole Ø	No. of Bolt Holes	Stud Bolt Ø	L	Size
	Outside Ø	Flange Thickness	R.F. Ø	Bolt Circle Ø				Bolt Length	
½	4 3/4	7/8	1 3/8	3 1/4	7/8	4	3/4	4 1/4	½
¾	5 1/8	1	1 6/8	3 1/2	7/8	4	3/4	4 1/2	¾
1	5 7/8	1 1/8	2	4	1	4	7/8	5	1
1¼	6 1/4	1 1/8	2 1/2	4 3/8	1	4	7/8	5	1¼
1½	7	1 1/4	2 7/8	4 7/8	1 1/8	4	1	5 1/2	1½
2	8 1/2	1 1/2	3 5/8	6 1/2	1	8	7/8	5 3/4	2
2½	9 5/8	1 5/8	4 1/8	7 1/2	1 1/8	8	1	6 1/4	2½
3	10 1/2	1 7/8	5	8	1 1/4	8	1 1/8	7	3
4	12 1/4	2 1/8	6 3/16	9 1/2	1 3/8	8	1 1/4	7 3/4	4
5	14 3/4	2 7/8	7 5/16	11 1/2	1 5/8	8	1 1/2	9 3/4	5
6	15 1/2	3 1/4	8 1/2	12 1/2	1 1/2	12	1 3/8	10 1/4	6
8	19	3 5/8	10 5/8	15 1/2	1 3/4	12	1 5/8	11 1/2	8
10	23	4 1/4	12 3/4	19	2	12	1 7/8	13 1/4	10
12	26 1/2	4 7/8	15	22 1/2	2 1/8	16	2	14 3/4	12
14	29 1/2	5 1/4	16 1/4	25	2 3/8	16	2 1/4	16	14
16	32 1/2	5 3/4	18 1/2	27 3/4	2 5/8	16	2 1/2	17 1/2	16
18	36	6 3/8	21	30 1/2	2 7/8	16	2 3/4	19 1/2	18
20	38 3/4	7	23	32 3/4	3 1/8	16	3	21 1/4	20
24	46	8	27 1/4	39	3 5/8	16	3 1/2	24 1/4	24

ANSI CLASS 150 PRESSURE-TEMP RATINGS

Temperature °F	Pressure (psig)										Temp. °C
	ANSI B16.34 Material Group										
	1.1	1.2	1.9	1.10	1.13	2.1		2.2		3.17	
	WCB ¹	LCC ²	WC6 ³	WC9 ³	C5 ³	CF8 ⁴	CF3 ⁵	CF8M ⁴	CF3M ⁶	CN7M ⁷	
-20 to 100	285	290	290	290	290	275	275	275	275	230	-29 to 38
200	260	260	260	260	260	230	230	235	235	200	93
300	230	230	230	230	230	205	205	215	215	180	149
350	215	215	215	215	215	198	198	205	205	170	177
400	200	200	200	200	200	190	190	195	195	160	204
450	185	185	185	185	185	180	180	183	183	155	232
500	170	170	170	170	170	170	170	170	170	150	260
550	155	155	155	155	155	155	155	155	155	145	288
600	140	140	140	140	140	140	140	140	140	140	316
650	125	125	125	125	125	125	125	125	125	125	343
700	110		110	110	110	110	110	110	110	110	371
750	95		95	95	95	95	95	95	95	95	399
800	80		80	80	80	80	80	80	80	80	427
850	65		65	65	65	65		65	65		454
900	50		50	50	50	50		50			482
950	35		35	35	35	35		35			510
1,000	20		20	20	20	20		20			538
1,050			20 ^a	20 ^a	20 ^a	20 ^a		20 ^a			566
1,100			20 ^a	20 ^a	20 ^a	20 ^a		20 ^a			593
1,150					20 ^a	20 ^a		20 ^a			621
1,200					15 ^a	20 ^a		20 ^a			649
1,250						20 ^a		20 ^a			677
1,300						20 ^a		20 ^a			704
1,350						20 ^a		20 ^a			732
1,400						20 ^a		20 ^a			760
1,450						15 ^a		20 ^a			788
1,500						10 ^a		20 ^a			816

¹ Upon prolonged exposure to temperatures above 800 °F (427 °C), the carbide phase of steel may be converted to graphite. Permissible, but not recommended for prolonged use above 800 °F (427 °C).

² Not to be used over 650 °F (343 °C).

³ Use normalized and tempered material only.

⁴ At temperatures over 1,000 °F (538 °C), use only when the carbon content is 0.04% or higher.

⁵ Not to be used over 800 °F (427 °C).

⁶ Not to be used over 850 °F (454 °C).

⁷ Use solution annealed material only.

^a For welding end valves only. Flanged end ratings terminate at 1,000 °F (538 °C).



API 600 CAST STEEL VALVES

ANSI CLASS 300 PRESSURE-TEMP RATINGS

Temperature °F	Pressure (psig)										Temp. °C
	ANSI B16.34 Material Group										
	1.1	1.2	1.9	1.10	1.13	2.1		2.2		3.17	
	WCB ¹	LCC ²	WC6 ³	WC9 ³	C5 ³	CF8 ⁴	CF3 ⁵	CF8M ⁴	CF3M ⁶	CN7M ⁷	
-20 to 100	740	750	750	750	750	720	720	720	720	600	-29 to 38
200	675	750	750	750	745	600	600	620	620	520	93
300	655	730	720	730	715	540	540	560	560	465	149
350	645	718	708	718	710	518	518	538	538	443	177
400	635	705	695	705	705	495	495	515	515	420	204
450	618	685	680	685	685	480	480	498	498	405	232
500	600	665	665	665	665	465	465	480	480	390	260
550	575	635	635	635	635	450	450	465	465	375	288
600	550	605	605	605	605	435	435	450	450	360	316
650	535	590	590	590	590	430	430	445	445		343
700	535		570	570	570	425	425	430	430		371
750	505		530	530	530	415	415	425	425		399
800	410		510	510	510	405	405	420	420		427
850	270		485	485	485	395		420	420		454
900	170		450	450	370	390		415			482
950	105		320	375	275	380		385			510
1,000	50		215	260	200	320		350			538
1,050			145 ^a	175 ^a	145 ^a	310 ^a		345 ^a			566
1,100			95 ^a	110 ^a	100 ^a	255 ^a		305 ^a			593
1,150					60 ^a	200 ^a		235 ^a			621
1,200					35 ^a	155 ^a		185 ^a			649
1,250						115 ^a		145 ^a			677
1,300						85 ^a		115 ^a			704
1,350						60 ^a		95 ^a			732
1,400						50 ^a		75 ^a			760
1,450						35 ^a		60 ^a			788
1,500						25 ^a		40 ^a			816

¹ Upon prolonged exposure to temperatures above 800 °F (427 °C), the carbide phase of steel may be converted to graphite. Permissible, but not recommended for prolonged use above 800 °F (427 °C).

² Not to be used over 650 °F (343 °C).

³ Use normalized and tempered material only.

⁴ At temperatures over 1,000 °F (538 °C), use only when the carbon content is 0.04% or higher.

⁵ Not to be used over 800 °F (427 °C).

⁶ Not to be used over 850 °F (454 °C).

⁷ Use solution annealed material only.

^a For welding end valves only. Flanged end ratings terminate at 1,000 °F (538 °C).

ANSI CLASS 600 PRESSURE-TEMP RATINGS

Temperature °F	Pressure (psig)										Temp. °C
	ANSI B16.34 Material Group										
	1.1	1.2	1.9	1.10	1.13	2.1		2.2		3.17	
	WCB ¹	LCC ²	WC6 ³	WC9 ³	C5 ³	CF8 ⁴	CF3 ⁵	CF8M ⁴	CF3M ⁶	CN7M ⁷	
-20 to 100	1,480	1,500	1,500	1,500	1,500	1,440	1,440	1,440	1,440	1,200	-29 to 38
200	1,350	1,500	1,500	1,500	1,490	1,200	1,200	1,240	1,240	1,035	93
300	1,315	1,455	1,445	1,455	1,430	1,080	1,080	1,120	1,120	930	149
350	1,293	1,433	1,415	1,433	1,420	1,038	1,038	1,073	1,073	888	177
400	1,270	1,410	1,385	1,410	1,410	995	995	1,025	1,025	845	204
450	1,235	1,370	1,358	1,370	1,370	963	963	990	990	813	232
500	1,200	1,330	1,330	1,330	1,330	930	930	955	955	780	260
550	1,148	1,270	1,270	1,270	1,270	903	903	928	928	750	288
600	1,095	1,210	1,210	1,210	1,210	875	875	900	900	720	316
650	1,075	1,175	1,175	1,175	1,175	860	860	890	890		343
700	1,065		1,135	1,135	1,135	850	850	870	870		371
750	1,010		1,065	1,065	1,055	830	830	855	855		399
800	825		1,015	1,015	1,015	805	805	845	845		427
850	535		975	975	965	790		835	835		454
900	345		900	900	740	780		830			482
950	205		640	755	550	765		775			510
1,000	105		430	520	400	640		700			538
1,050			290 ^a	350 ^a	290 ^a	615 ^a		685 ^a			566
1,100			190 ^a	220 ^a	200 ^a	515 ^a		610 ^a			593
1,150					125 ^a	400 ^a		475 ^a			621
1,200					70 ^a	310 ^a		370 ^a			649
1,250						225 ^a		295 ^a			677
1,300						170 ^a		235 ^a			704
1,350						125 ^a		190 ^a			732
1,400						95 ^a		150 ^a			760
1,450						70 ^a		115 ^a			788
1,500						55 ^a		85 ^a			816

¹ Upon prolonged exposure to temperatures above 800 °F (427 °C), the carbide phase of steel may be converted to graphite. Permissible, but not recommended for prolonged use above 800 °F (427 °C).

² Not to be used over 650 °F (343 °C).

³ Use normalized and tempered material only.

⁴ At temperatures over 1,000 °F (538 °C), use only when the carbon content is 0.04% or higher.

⁵ Not to be used over 800 °F (427 °C).

⁶ Not to be used over 850 °F (454 °C).

⁷ Use solution annealed material only.

^a For welding end valves only. Flanged end ratings terminate at 1,000 °F (538 °C).



API 600 CAST STEEL VALVES

ANSI CLASS 900 PRESSURE-TEMP RATINGS

Temperature °F	Pressure (psig)										Temp. °C
	ANSI B16.34 Material Group										
	1.1	1.2	1.9	1.10	1.13	2.1		2.2		3.17	
	WCB ¹	LCC ²	WC6 ³	WC9 ³	C5 ³	CF8 ⁴	CF3 ⁵	CF8M ⁴	CF3M ⁶	CN7M ⁷	
-20 to 100	2,220	2,250	2,250	2,250	2,250	2,160	2,160	2,160	2,160	1,800	-29 to 38
200	2,025	2,250	2,250	2,250	2,235	1,800	1,800	1,860	1,860	1,555	93
300	1,970	2,185	2,165	2,185	2,150	1,620	1,620	1,680	1,680	1,395	149
350	1,935	2,150	2,123	2,150	2,133	1,555	1,555	1,610	1,610	1,330	177
400	1,900	2,115	2,080	2,115	2,115	1,490	1,490	1,540	1,540	1,265	204
450	1,848	2,055	2,038	2,055	2,055	1,443	1,443	1,488	1,488	1,215	232
500	1,795	1,995	1,995	1,995	1,995	1,395	1,395	1,435	1,435	1,165	260
550	1,718	1,905	1,905	1,905	1,905	1,353	1,353	1,395	1,395	1,123	288
600	1,640	1,815	1,815	1,815	1,815	1,310	1,310	1,355	1,355	1,080	316
650	1,610	1,765	1,765	1,765	1,765	1,290	1,290	1,330	1,330		343
700	1,600		1,705	1,705	1,705	1,275	1,275	1,305	1,305		371
750	1,510		1,595	1,595	1,585	1,245	1,245	1,280	1,280		399
800	1,235		1,525	1,525	1,525	1,210	1,210	1,265	1,265		427
850	805		1,460	1,460	1,450	1,190		1,255	1,255		454
900	515		1,350	1,350	1,110	1,165		1,245			482
950	310		955	1,130	825	1,145		1,160			510
1,000	155		650	780	595	965		1,050			538
1,050			430 ^a	525 ^a	430 ^a	925 ^a		1,030 ^a			566
1,100			290 ^a	330 ^a	300 ^a	770 ^a		915 ^a			593
1,150					185 ^a	595 ^a		710 ^a			621
1,200					105 ^a	465 ^a		555 ^a			649
1,250						340 ^a		440 ^a			677
1,300						255 ^a		350 ^a			704
1,350						185 ^a		290 ^a			732
1,400						145 ^a		225 ^a			760
1,450						105 ^a		175 ^a			788
1,500						80 ^a		125 ^a			816

¹ Upon prolonged exposure to temperatures above 800 °F (427 °C), the carbide phase of steel may be converted to graphite. Permissible, but not recommended for prolonged use above 800 °F (427 °C).

² Not to be used over 650 °F (343 °C).

³ Use normalized and tempered material only.

⁴ At temperatures over 1,000 °F (538 °C), use only when the carbon content is 0.04% or higher.

⁵ Not to be used over 800 °F (427 °C).

⁶ Not to be used over 850 °F (454 °C).

⁷ Use solution annealed material only.

^a For welding end valves only. Flanged end ratings terminate at 1,000 °F (538 °C).

ANSI CLASS 1500 PRESSURE-TEMP RATINGS

Temperature °F	Pressure (psig)										Temp. °C
	ANSI B16.34 Material Group										
	1.1	1.2	1.9	1.10	1.13	2.1		2.2		3.17	
	WCB ¹	LCC ²	WC6 ³	WC9 ³	C5 ³	CF8 ⁴	CF3 ⁵	CF8M ⁴	CF3M ⁶	CN7M ⁷	
-20 to 100	3,705	3,750	3,750	3,750	3,750	3,600	3,600	3,600	3,600	3,000	-29 to 38
200	3,375	3,750	3,750	3,750	3,725	3,000	3,000	3,095	3,095	2,590	93
300	3,280	3,640	3,610	3,640	3,580	2,700	2,700	2,795	2,795	2,330	149
350	3,225	3,585	3,538	3,585	3,555	2,593	2,593	2,683	2,683	2,220	177
400	3,170	3,530	3,465	3,530	3,530	2,485	2,485	2,570	2,570	2,110	204
450	3,083	3,428	3,395	3,428	3,428	2,408	2,408	2,480	2,480	2,028	232
500	2,995	3,325	3,325	3,325	3,325	2,330	2,330	2,390	2,390	1,945	260
550	2,865	3,175	3,175	3,175	3,175	2,258	2,258	2,323	2,323	1,873	288
600	2,735	3,025	3,025	3,025	3,025	2,185	2,185	2,255	2,255	1,800	316
650	2,685	2,940	2,940	2,940	2,940	2,150	2,150	2,220	2,220		343
700	2,665		2,840	2,840	2,840	2,125	2,125	2,170	2,170		371
750	2,520		2,660	2,660	2,640	2,075	2,075	2,135	2,135		399
800	2,060		2,540	2,540	2,540	2,015	2,015	2,110	2,110		427
850	1,340		2,435	2,435	2,415	1,980		2,090	2,090		454
900	860		2,245	2,245	1,850	1,945		2,075			482
950	515		1,595	1,885	1,370	1,910		1,930			510
1,000	260		1,080	1,305	995	1,605		1,750			538
1,050			720 ^a	875 ^a	720 ^a	1,545 ^a		1,720 ^a			566
1,100			480 ^a	550 ^a	495 ^a	1,285 ^a		1,525 ^a			593
1,150					310 ^a	995 ^a		1,185 ^a			621
1,200					170 ^a	770 ^a		925 ^a			649
1,250						565 ^a		735 ^a			677
1,300						430 ^a		585 ^a			704
1,350						310 ^a		480 ^a			732
1,400						240 ^a		380 ^a			760
1,450						170 ^a		290 ^a			788
1,500						135 ^a		205 ^a			816

¹ Upon prolonged exposure to temperatures above 800 °F (427 °C), the carbide phase of steel may be converted to graphite. Permissible, but not recommended for prolonged use above 800 °F (427 °C).

² Not to be used over 650 °F (343 °C).

³ Use normalized and tempered material only.

⁴ At temperatures over 1,000 °F (538 °C), use only when the carbon content is 0.04% or higher.

⁵ Not to be used over 800 °F (427 °C).

⁶ Not to be used over 850 °F (454 °C).

⁷ Use solution annealed material only.

^a For welding end valves only. Flanged end ratings terminate at 1,000 °F (538 °C).



API 600 CAST STEEL VALVES

SHELL MATERIAL SPECIFICATIONS

Carbon and Alloy Steel Castings						
	Unit	A216 Gr. WCB	A352 Gr. LCC	A217 Gr. WC6	A217 Gr. WC9	A217 Gr. C5
C ¹	%	0.300 ³	0.250 ⁴	0.05-0.20	0.05-0.18	0.200
Si ¹	%	0.600				0.750
Mn ¹	%	1.000 ³	1.200 ⁴	0.50-0.80	0.40-0.70	
P ¹	%	0.040				
S ¹	%	0.045				
Cr ¹	%	0.500	0.500 ⁵	1.00-1.50	2.00-2.75	4.00-6.50
Ni ¹	%	0.500	0.500 ⁵	0.500		
Mo ¹	%	0.200	0.200 ⁵	0.45-0.65	0.90-1.20	0.45-0.65
Cu ¹	%	0.300	0.300 ⁵	0.500		
V ¹	%	0.030	0.030 ⁵	-		
T.S.	MPa	485-655				620-795
Y.S. ²	MPa	250	275			415
EI. ²	%	22.0		20.0		18.0
R.A. ²	%	35.0				

Corrosion Resistant Steel Castings						
	Unit	A351 Gr. CF8	A351 Gr. CF8M	A351 Gr. CF3	A351 Gr. CF3M	A351 Gr. CN7M
C ¹	%	0.08		0.03		0.07
Si ¹	%	2.00	1.50	2.00	1.50	
Mn ¹	%	1.50				
P ¹	%	0.04				
S ¹	%	0.04				
Cr	%	18.0-21.0		17.0-21.0		19.0-22.0
Ni	%	8.0-11.0	9.0-12.0	8.0-12.0	9.0-13.0	27.5-30.5
Mo ¹	%	0.50	2.0-3.0	0.50	2.0-3.0	
Cu	%	-				3.0-4.0
T.S. ²	MPa	485				425
Y.S. ²	MPa	205				170
EI. ²	%	35.0				

¹ Values listed are permitted maximums, unless otherwise stated.

² Values listed are required minimums, unless otherwise stated.

³ For each reduction of 0.01% below the specified maximum carbon content, an increase of 0.04% Mn above the specified maximum will be permitted up to a maximum of 1.28%.

⁴ For each reduction of 0.01% below the specified maximum carbon content, an increase of 0.04% Mn above the specified maximum will be permitted up to a maximum of 1.40%.

⁵ Specified Residual Elements - The total content of these elements is 1.00% maximum.

TRIM MATERIAL SPECIFICATIONS

Corrosion Resistant Alloys					
	Unit	A182 Gr. F6a	A182 Gr. F304	A182 Gr. F316	A182 Gr. F347 ³
C ¹	%	0.150		0.080	
Si ¹	%		1.000		
Mn ¹	%	1.000		2.000	
P ¹	%		0.040		
S ¹	%		0.030		
Cr	%	11.5-13.5	18.0-20.0	16.0-18.0	17.0-20.0
Ni ¹	%	0.500	8.0-11.0	10.0-14.0	9.0-13.0
Mo	%	-		2.0-3.0	-
N ¹	%	-	0.100		-
Tensile Str. ²	MPa	485		515 ⁴	
Yield Str. ²	MPa	275		205	
Elongation ²	%	18.0		30.0	
Reduc. of Area ²	%	35.0		50.0	
Hardness	HB	143-187		-	
Nonferrous Alloys			Bolting		
	Unit	Alloy 20 ⁵ B462 UNS N08020	Ni-Cu Alloy UNS N04400 B164	Alloy Steel A193 Gr. B7	Carbon Steel A194 Gr. 2H
C ¹	%	0.070	0.300	0.37-0.49	0.400 Min.
Si ¹	%	1.000	0.500	0.15-0.35	0.400
Mn ¹	%	2.000		0.65-1.10	1.000
P ¹	%	0.045	-	0.035	0.040
S ¹	%	0.035	0.024	0.040	0.050
Cr	%	19.0-21.0	-	0.75-1.20	-
Ni ²	%	32.0-38.0	63.0 ⁶	-	-
Mo ¹	%	2.0-3.0	-	0.15-0.25	-
Cu ¹	%	3.0-4.0	28.0-34.0	-	-
Fe ¹	%	Balance ⁶	2.500	-	-
Tensile Str. ²	MPa	551	480	860	-
Yield Str. ²	MPa	241	170	720	-
Elongation ²	%	30.0	35.0	18.0	-
Reduc. of Area ²	%	50.0	-	50.0	-

¹ Values listed are permitted maximums, unless otherwise stated.

² Values listed are required minimums, unless otherwise stated.

³ Shall have a columbium plus tantalum content of not less than ten times the carbon content and not more than 1.10%.

⁴ For sections over 5 inches in thickness, the minimum tensile strength shall be 485 MPa.

⁵ Shall have a columbium plus tantalum content of not less than eight times the carbon content and not more than 1.0%.

⁶ Shall be determined arithmetically by difference.



API 600 CAST STEEL VALVES

FIGURE NUMBER COMPARISON CHART

Valve	ANSI Class	DPV®	Crane	Kitz	Lunkenheimer	Newco
Gate	150	1512F	47	150SCL	1512	11F-CB
	300	3012F	33	300SCL	3012	13F-CB
	600	6012F	76	600SCL	6012	16F-CB
	900	9012F	83	900SCL	-	19F-CB
	1500	15012F	87	1500SCL	-	115F-CB
Globe	150	1522F	143	150SCJ	1542	21F-CB
	300	3022F	151	300SCJ	3042	23F-CB
	600	6022F	171	600SCJ	6042	26F-CB
	900	9022F	183	900SCJ	-	29F-CB
	1500	15022F	189	1500SCJ	-	215F-CB
Swing Check	150	1532F	147	150SCO	1572	31F-CB
	300	3032F	159	300SCO	3072	33F-CB
	600	6032F	175	600SCO	6072	36F-CB
	900	9032F	187	900SCO	-	39F-CB
	1500	15032F	199	1500SCO	-	315F-CB

Valve	ANSI Class	Pacific	Powell	Stockham	Velan	Walworth
Gate	150	2155	1503N / 1503	15-OF	F-0064C-02	5202F
	300	2355	3003N / 3003	30-OF	F-1064C-02	5206F
	600	2655	6003	60-OF	F-2064C-02	5232F
	900	2955	9003	-	F-7064C-02	5247F
	1500	21555	1303	-	F-3064C-02	5262F
Globe	150	160	1531	15-GPF	F-0074C-02	5275F
	300	360	3031	30-GPF	F-1074C-02	5281F
	600	660	6031	60-GPF	F-2074C-02	5295F
	900	960	9031	-	F-7074C-02	5301F
	1500	-	1331	-	F-3074C-02	5308F
Swing Check	150	180 / 184	1561	15-SF	F-0114C-02	5341F
	300	380 / 384	3061	30-SF	F-1114C-02	5344F
	600	680 / 684	6061	60-SF	F-2114C-02	5350F
	900	984	9061	-	F-7114C-02	5353F
	1500	1584	1361	-	F-3114C-02	5356F

STANDARD TERMS AND CONDITIONS OF SALE

CONTROLLING PROVISIONS AND ACCEPTANCE

All DPV sales are expressly subject to these terms and conditions, which govern and prevail regardless of any terms and conditions set forth to the contrary by the Buyer. The Buyer's acceptance of these terms and conditions is evidenced by the Buyer's placement of order with DPV.

QUOTATIONS AND PRICES

All goods are priced F.O.B. our warehouse. Inland freight to destination is for account of the Buyer, either on collect basis, or prepaid and then billed by DPV for payment by the Buyer. Unless otherwise stated in writing, all prices are valid for thirty (30) days only. Published prices are subject to changes without prior notice.

DELIVERY

Delivery quoted is estimated based on availability of DPV's stock and/or production schedule at time of quotation/order, and is subject to changes in the event of prior sales and re-scheduling to any occurrences beyond the DPV's control, though DPV, as a gesture of goodwill, will do its best stay as close as possible to the delivery estimated. Title to the product(s) and risk of loss shall pass to the Buyer upon delivery to a common carrier or Buyer's transport. All claims of loss to the materials in transit shall be filed by the Buyer directly with the carrier. All claims for shortages, corrections or deductions must be made to DPV within ten (10) days after receipt of goods.

CANCELLATION AND RETURN

All cancellations and returns, etc., cannot be made without DPV's formal prior consent with a Return Authorization Number (RAN). A cancellation and re-stocking charge will apply in accordance with DPV's Return Policy, which applies to all returns. Special items are not subject to cancellation or returns.

FORCE MAJEURE

DPV is not to be held responsible for any delays in delivery, or defaults in completing an order or contract, due to force majeure such as strikes, work stoppages, fires, floods, accidents, inability to obtain fuel and transportation means, vendors' delayed deliveries or materials, parts, components, goods, etc., to DPV, acts of God, and/or any other causes beyond Seller's control.

TAXES

All DPV prices are exclusive of all taxes, which, if applicable under government laws, shall be wholly for the Buyer's account and to be fully paid by the Buyer only. Where the Buyer is lawfully entitled to exemption from any tax, all necessary documentation must be provided by the Buyer to DPV to effect such exemption. Any taxes interests and penalties assessed against DPV on transactions which are otherwise determined as taxable, shall be borne by the Buyer. The term "Taxes" used here shall include any impost, duty, levy or other charges imposed by any government or agency thereof upon the property, services or parties hereto, but shall not include those measured by the net income of DPV.

ERRORS

All clerical and computational errors and/or omissions are exempted and are to be corrected by DPV.

LIMITED WARRANTY

All DPV products are guaranteed to the original Buyer only for a one (1) year period from and after the invoice date against defects in material and workmanship under normal and proper use and service, and not caused or resulting from improper usage or application, improper installation, improper maintenance and repairs, modifications or alterations, normal wear and tears, corrosion, erosion, or chemical attacks. DPV's obligation under this warranty is limited strictly to repairing or replacing, at its election, any parts or products determined by DPV to be defective, or refunding the purchasing price to the original Buyer. DPV shall bear normal surface transportation cost for shipping the replacements, but shall not bear any losses, damages, installation, re-installation, engineering, or any other costs incurred thereof by the Buyer. The Uniform Commercial Code (UCC) shall not apply to the sale, nor the Michigan statutes adopting the UCC. This warranty is expressly made in lieu of and excludes all other warranties, guarantees, or representations expressed or implied. There are no implied warranties of merchantability or fitness for a particular purpose.

EXCLUSIONS

Do not use DPV products in aircraft or aerospace applications. No warranties, guarantees or representations of any kind are made with respect to such applications. The Buyer assumes on their own all risks of any use in such applications and will indemnify and hold harmless DPV against and from any claims, costs (including attorney's fees) and liabilities arising out of such use.

LIABILITY

Notwithstanding any provision in the Buyer's order or elsewhere to the contrary, under no circumstances shall DPV be liable for any direct, indirect, special, consequential or incidental damages (including but not limited to loss of revenue, loss of use, material, production or end products), or any other claims for damages arising out of the purchase, delivery, installation or use of DPV products, whether claimed in contract, warranty, tort (including negligence) and delays, actual or imputed, or otherwise.

GOVERNING LAW

The contract shall be governed by, construed, and enforced in accordance with the laws of the State of New York in the United States of America. The provisions of the "UN Convention on Contracts for the International Sale of Goods" shall not apply.

OTHER PRODUCTS

API 6D / BS 5351 Floating Ball Valves

Fire Tested & Certified to API 6FA & BS 6755 Pt. 2
1-Pce & 2-Pce Body Design, Full & Reduced Bores
ANSI Class 150 & 300, ½" to 12", WCB/LCC/CF8M

API 609 Butterfly Valves

Category A, Wafer & Lug Body Patterns
Concentric Disc & Seat Design, 2-Pce Stem
Rated 200 psig CWP, 2" to 12", WCB & CF8M

Industrial Ball Valves - Investment Cast

1-Pce, 2-Pce & 3 Pce Body Designs
Full & Reduced Bores, NPT/SW/BW Ends
ANSI Class 150 to 800, ½" to 4", WCB & CF8M

Multi-Function Control Check Valves

Y-Pattern Body, Cast & Ductile Iron, 2" to 14"
ANSI Class 125, 150 & 300, Flanged Ends

API 6D Trunnion Mounted Ball Valves

Forged Steel, 3-Piece Bolted Body Design
ANSI Cl.150 to 2500, Full & Reduced Bores
Available in A105, LF2 and other Alloys

API 6D / API 594 Wafer Check Valves

Dual & Single Plate Designs
ANSI Class 150 to 600, 2" to 24"
Available in WCB, LCB & CF8M

Industrial Strainers

Y & Basket (Simplex & Duplex) Types
ANSI Class 150 to 1500, ¼" to 16"
Available in Cast Iron, Bronze, WCB & CF8M

Pump Suction Diffusers

Cast Iron & Ductile Iron Materials
ANSI Class 125, 150 & 300, Flanged Ends

Corporate Head Office

DELTA PACIFIC VALVE MFG CO



Tel:

C

.com