

DPV<sup>®</sup>

DPV-UK LTD

DIN EN Steel Valves



Services ●

Talent ●

Quality ●

Innovation ●

DPV-UK LTD



# DIN EN STEEL VALVES

## TABLE OF CONTENTS

Page	Title	Page	Title
01	Table of Contents/How to Order	12	Globe Valve PN06-PN16 (Cast Steel)
02	Company Introduction	13	Globe Valve PN25-PN63(Cast Steel)
03	Gate Valve Design of Features(Forged Steel)	14	Globe Valve PN100-PN160(Cast Steel)
04	Gate Valve Materials of Construction	15	Piston Check Valve Design of Features(Cast Steel)
05	Gate Valve PN06-PN250(Forged Steel)	16	Piston Check Valve Materials of Canstruction
06	Gate Valve Design of Features(Cast Steel)	17	Piston Check Valve PN06-PN16(Cast Steel)
07	Gate Valve Materials of Construction	18	Piston Check Valve PN25-PN40(Cast Steel)
08	Gate Valve PN06-PN25(Cast Steel)	19	Swing Check Valve Design of Features(Cast Steel)
09	Gate Valve PN40-PN160(Cast Steel)	20	Swing Check Valve Materials of Construction
10	Globe Valve Design of Features(Cast Steel)	21	Swing Check Valve PN06-PN25(Cast Steel)
11	Globe Valve Materials of Construction	22	Swing Check Valve PN40-PN100(Cast Steel)

## HOW TO ORDER

Pressure(PN)	Valve Type	Body Material	Ends Connections	Extras
<b>16</b>	<b>1</b>	<b>3</b>	<b>F</b>	<b>B</b>
06=PN6 10=PN10 16=PN16 25=PN25 40=PN40 63=PN63 100=PN100 160=PN160 250=PN250 320=PN320 400=PN400	1=Gate 2=Globe 3=Piston Check 4=Swing Check	1=Forged CS 2=Forged SS 3=Cast CS 4=Cast SS 5=Chrome Molys 6=Low Temp CS 7=Duplex 8=Super Duplex 9=Monel X=Other	F=Flanged B=Butt Weld H=Hub Ended	(C)=Cryogenic (B)=Bellows (J)=Jacketed

Example: 1613F(B)=PN16 Gate Valve in carbon steel with flanged ends and bellows

# DIN EN CAST STEEL VALVES



## COMPANY INTRODUCTION

DPV-UK Ltd have been manufacturing valves since 1983, consistent product quality and availability of substantial stocks makes DPV-UK Ltd a dependable choice for forged and cast valves in carbon, stainless and alloy materials.

DPV-UK Ltd manufacture valves to industry standard specifications or can be made to meet specific requirements both quickly and Economically.

DPV-UK Ltd quality assurance is dedicated to supply valves manufactured and tested in full compliance to the clients technical specifications and other required applicable standards, Our extensive quality control system carefully monitors raw materials, manufacturing process's and final valves inspection to assure supply is of the highest quality of valves to our clients.



## GATE VALVE DESIGN FEATURES

- Plain or One-Piece Solid Wedge
- Bolted Bonnet Construction
- Outside Screw and Yoke
- Non-Rotating,Rising Stem
- Manual Operated,Actuation Available
- Renewable Seat-In Seat Rings
- Design :EN 1984/BS 5352
- Shell Thickness :BS 5352
- Flanged :EN 1092-1/DIN2543-2547
- Face To Face :DIN 3202
- Testing :DIN 3230/EN 12266-1,2

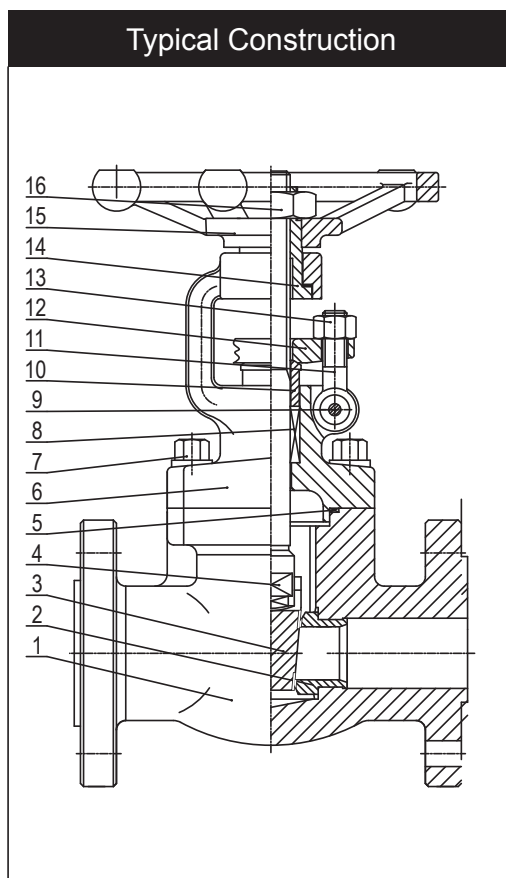

No.	Part Name
1	Body
2	Seat
3	Wedge Disc
4	Stem
5	Gasket
6	Bonnet
7	Bolts
8	Packing
9	Pin
10	Gland
11	Eyebolt
12	Gland Flange
13	Eyenut
14	Stem Nut
15	Handwheel
16	Handwheel Nut

# GATE VALVES(FORGED)



## STANDARD MATERIALS OF CONSTRUCTION

Part Name	EN 10218,EN10222 Material Group					
	Carbon Steel		C-Mo Steel	C-Cr-Mo Steel		
Material Name	P250GH	P245GH	16Mo3	13CrMo4-5	10CrMo9-10	
Material Number	1.0460	1.0352	1.5415	1.7335	1.7380	
Body/Bonnet	1.0460	1.0352	1.5415	1.7335	1.7380	
Wedge/Disc	The same as Body/Other materials available upon request					
Stem	1.4021/Materials available upon request					
Bolts/Nuts	B7(M)/2H(M)			B16/4		
Gland Flange	The same as Body/Other materials available upon request					
Stem Nut	Austenitic Ductile Iron/Other materials available upon request					
Handwheel	Ductile /Malleable Iron					
Handwheel Nut	Carbon Steel					
Gland Bolts/Nuts	B7(M)/2H(M)			B16/4		
Part Name	Corrosion Resistant Steel					
Material Name	X5CrNi18-10	X2CrNi19-11	X5CrNi-Mo17-12-2	X2CrNi-Mo17-12-2	X6CrNiTi-18-10	X6CrNiNb-18-10
Material Number	1.4301	1.4306	1.4401	1.4404	1.4541	1.4550
Body/Bonnet	1.4301	1.4306	1.4401	1.4404	1.4541	1.4550
Wedge/Disc	The same as Body/Other materials available upon request					
Stem	1.4301	1.4306	1.4401	1.4404	1.4541	1.4550
Bolts/Nuts	B8(M)/8(M)					
Gland Flange	The same as Body/Other materials available upon request					
Stem Nut	Austenitic Ductile Iron/Other materials available upon request					
Handwheel	Ductile /Malleable Iron					
Handwheel Nut	Carbon Steel					
Gland Bolts/Nuts	B8(M)/8(M)					

Note:Other materials available upon request



# GATE VALVES(FORGED)

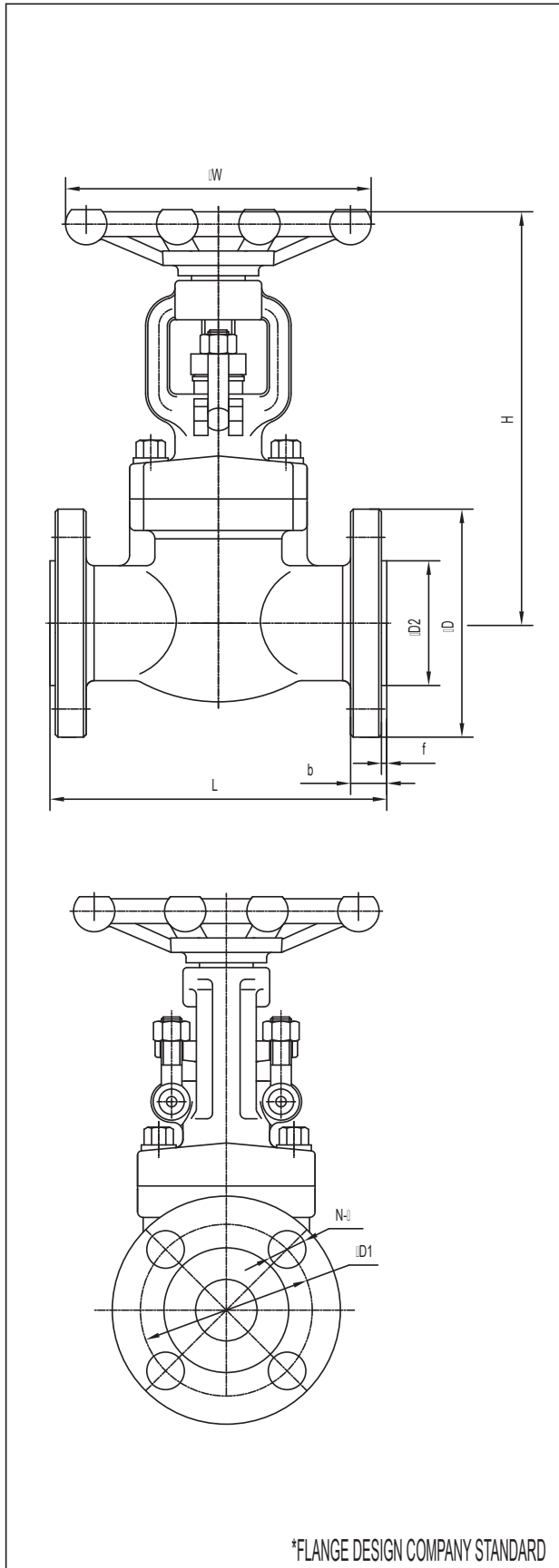

\*FLANGE DESIGN COMPANY STANDARD

DPV Figure Numbers									
Material	DIN EN PN								
	PN06	PN10	PN16	PN25	PN40	PN63	PN100	PN160	PN250
Forged CS	0611F	1011F	1611F	2511F	4011F	6311F	10011F	16011F	25011F
Forged SS	0612F	1012F	1612F	2512F	4012F	6312F	10012F	16012F	25012F
Chrome Molys	0615F	1015F	1615F	2515F	4015F	6315F	10015F	16015F	25015F
Low Temp CS	0616F	1016F	1616F	2516F	4016F	6316F	10016F	16016F	25016F
Duplex	0617F	1017F	1617F	2517F	4017F	6317F	10017F	16017F	25017F
Super Duplex	0618F	1018F	1618F	2518F	4018F	6318F	10018F	16018F	25018F
Monel	0619F	1019F	1619F	2519F	4019F	6319F	10019F	16019F	25019F

PN06				Diameter (mm)						
DN	L	H	W	D	D1	D2	b	f	N-Ø	Weight(Kg)
15	130	158	100	80	55	40	12	2.0	4-11	4.8
20	150	161	100	90	65	50	14	2.0	4-11	6.2
25	160	189	120	100	75	60	14	2.0	4-11	9.3
32	180	235	160	120	90	70	14	2.0	4-14	13.5
40	240	250	160	130	100	80	14	3.0	4-14	15.5
50	250	290	180	140	110	90	14	3.0	4-14	23.5

PN10/16				Diameter (mm)						
DN	L	H	W	D	D1	D2	b	f	N-Ø	Weight(Kg)
15	130	158	100	95	65	45	16	2.0	4-14	4.9
20	150	161	100	105	75	58	18	2.0	4-14	6.4
25	160	189	120	115	85	68	18	2.0	4-14	9.6
32	180	235	160	140	100	78	18	2.0	4-18	14.2
40	240	250	160	150	110	88	18	3.0	4-18	16.5
50	250	290	180	165	125	102	18	3.0	4-18	24.2

PN25/40				Diameter (mm)						
DN	L	H	W	D	D1	D2	b	f	N-Ø	Weight(Kg)
15	130	158	100	95	65	45	16	2.0	4-14	4.9
20	150	161	100	105	75	58	18	2.0	4-14	6.4
25	160	189	120	115	85	68	18	2.0	4-14	9.6
32	180	235	160	140	100	78	18	2.0	4-18	14.2
40	240	250	160	150	110	88	18	3.0	4-18	16.5
50	250	290	180	165	125	102	20	3.0	4-18	24.5

PN63				Diameter (mm)						
DN	L	H	W	D	D1	D2	b	f	N-Ø	Weight(Kg)
15	170	161	100	105	75	45	20	2.0	4-14	5.9
20	190	189	120	130	90	58	22	2.0	4-18	7.4
25	210	235	160	140	100	68	24	2.0	4-18	10.4
32	230	250	160	155	110	78	26	2.0	4-22	16.2
40	240	290	180	170	125	88	28	3.0	4-22	17.5
50	250	325	200	180	135	102	26	3.0	4-22	25.6

PN100				Diameter (mm)						
DN	L	H	W	D	D1	D2	b	f	N-Ø	Weight(Kg)
15	170	161	100	105	75	45	20	2.0	4-14	5.9
20	190	189	120	130	90	58	22	2.0	4-18	7.4
25	210	235	160	140	100	68	24	2.0	4-18	10.4
32	230	250	160	155	110	78	26	2.0	4-22	16.2
40	240	290	180	170	125	88	28	3.0	4-22	17.5
50	250	325	200	195	145	102	30	3.0	4-26	26.5

PN160				Diameter (mm)						
DN	L	H	W	D	D1	D2	b	f	N-Ø	Weight(Kg)
15	170	161	100	105	75	45	20	2.0	4-14	5.9
20 *	190	189	120	130	90	58	22	2.0	4-18	7.4
25	210	235	160	140	100	68	24	2.0	4-18	10.4
32 *	230	250	160	155	110	78	26	2.0	4-22	16.2
40	240	290	180	170	125	88	28	3.0	4-22	17.5
50	250	325	200	195	145	102	30	3.0	4-26	26.5

PN250				Diameter (mm)						
DN	L	H	W	D	D1	D2	b	f	N-Ø	Weight(Kg)
15	170	161	100	130	90	45	26	2.0	4-18	5.9
20 *	190	189	120	140	100	58	28	2.0	4-18	7.4
25	210	235	160	150	105	68	28	2.0	4-22	10.4
32 *	230	250	160	170	125	78	30	2.0	4-22	16.2
40	240	290	180	185	135	88	34	3.0	4-26	17.5
50	250	325	200	200	150	102	38	3.0	8-26	26.5

# GATE VALVES(CAST)



## GATE VALVE DESIGN FEATURES

- Plain or One-Piece Flexible Solid Wedge
- Bolted Bonnet Construction
- Outside Screw and Yoke
- Non-Rotating,Rising Stem
- Manual Operated,Actuation Available
- Design :EN 1984/DIN 3352
- Shell Thickness :EN 1984/DIN 3352
- Flanged :EN 1092-1/DIN2543-2547
- Face To Face :DIN 3202
- Testing :DIN 3230/EN 12266-1,2

Typical Construction

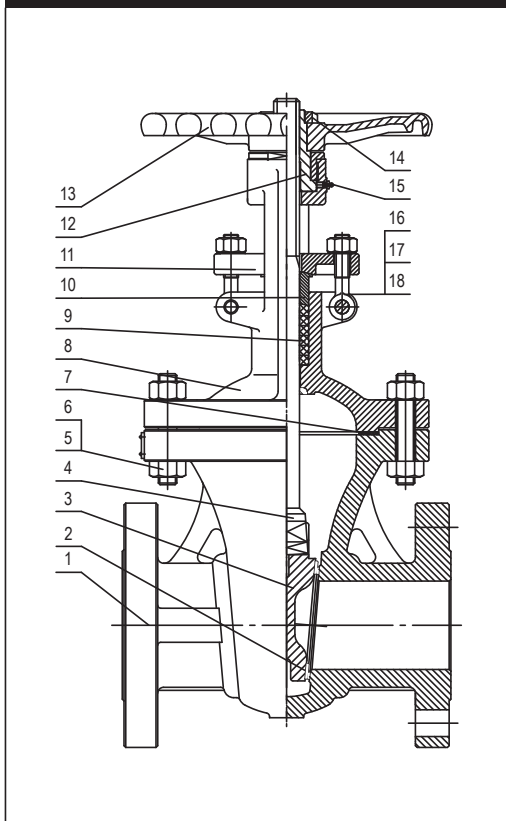

No.	Part Name
1	Body
2	Seal face
3	Wedge Disc
4	Stem
5	Bolts
6	Nuts
7	Gasket
8	Bonnet
9	Packing
10	Gland
11	Gland Flange
12	Stem Nut
13	Handwheel
14	Handwheel Nut
15	Grease Fitting
16	Eyebolt
17	Eye nut
18	Pin



# GATE VALVES(CAST)

## STANDARD MATERIALS OF CONSTRUCTION

Part Name	EN 10213 Material Group					
	Carbon Steel	C-Mn Steel		C-Mo Steel	C-Cr-Mo Steel	
Material Name	GP240GH	G17Mn5	G20Mn5	G20Mo5	G17CrMo5-5	G17CrMo9-10
Material Number	1.0619	1.1131	1.6220	1.5419	1.7357	1.7379
Body/Bonnet	1.0619	1.1131	1.6220	1.5419	1.7357	1.7379
Wedge/Disc	The same as Body/Other materials available upon request					
Stem	1.4021/Materials available upon request					
Bolts/Nuts	B7(M)/2H(M)	L7(M)/7(M)		B16/4		
Gland Flange	The same as Body/Other materials available upon request					
Stem Nut	Austenitic Ductile Iron/Other materials available upon request					
Handwheel	Ductile /Malleable Iron					
Handwheel Nut	Carbon Steel					
Gland Bolts/Nuts	B7(M)/2H(M)	L7(M)/7(M)		B16/4		
Part Name	Corrosion Resistant Steel					
	GX5CrNi19-10	GX2CrNi19-11	GX5CrNi-Mo19-11-2	GX2CrNi-Mo19-11-2	GX5CrNi-Nb19-11	GX2NiCr-Mo28-20-2
Material Name	GX5CrNi19-10	GX2CrNi19-11	GX5CrNi-Mo19-11-2	GX2CrNi-Mo19-11-2	GX5CrNi-Nb19-11	GX2NiCr-Mo28-20-2
Material Number	1.4308	1.4309	1.4408	1.4409	1.4552	1.4458
Body/Bonnet	1.4308	1.4309	1.4408	1.4409	1.4552	1.4458
Wedge/Disc	The same to Body/Other materials available upon request					
Stem	1.4301	1.4306	1.4401	1.4404	1.4541	ALLOY 20
Bolts/Nuts	B8(M)/8(M)					
Gland Flange	The same as Body/Other materials available upon request					
Stem Nut	Austenitic Ductile Iron/Other materials available upon request					
Handwheel	Ductile /Malleable Iron					
Handwheel Nut	Carbon Steel					
Gland Bolts/Nuts	B8(M)/8(M)					

Note:Other materials available upon request



# GATE VALVES(CAST)



## DIN 3202-F4(FACE-FACE)

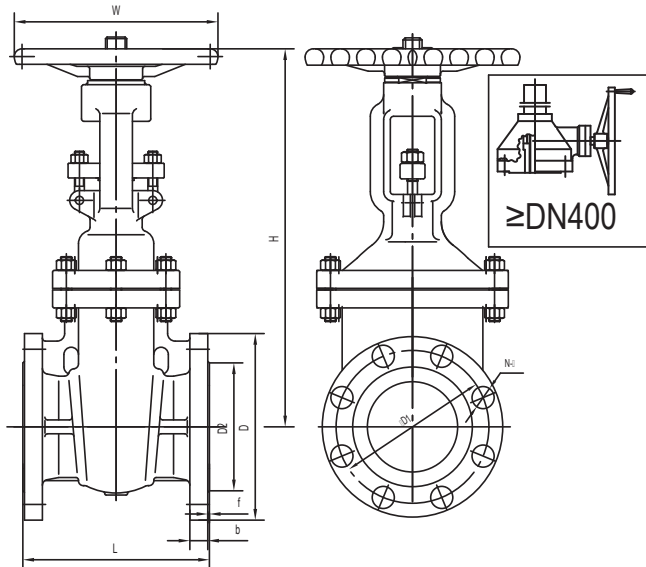

## DIN 3202-F5(FACE-FACE)

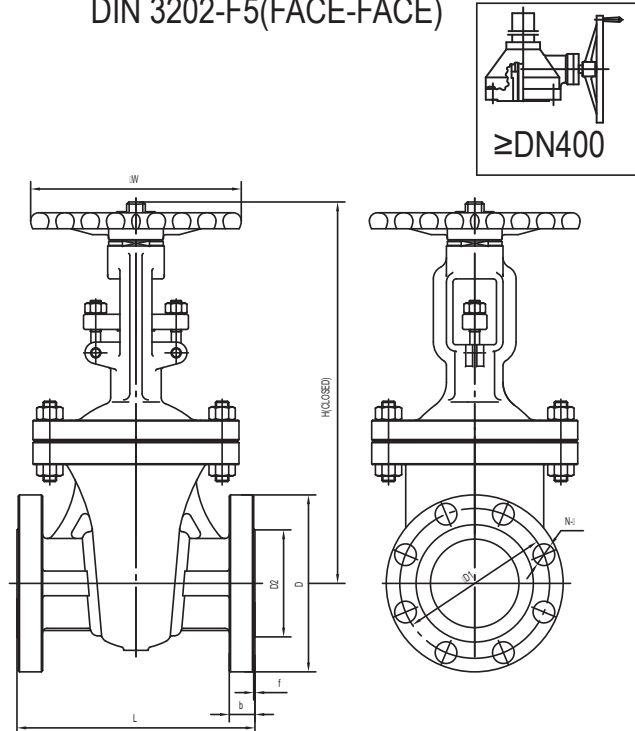

### DPV Figure Numbers

Material	DIN EN PN			
	PN06	PN10	PN16	PN25
Cast CS	0613F	1013F	1613F	2513F
Cast SS	0614F	1014F	1614F	2514F
Chrome Molys	0615F	1015F	1615F	2515F
Low Temp CS	0616F	1016F	1616F	2516F
Duplex	0617F	1017F	1617F	2517F
Super Duplex	0618F	1018F	1618F	2518F
Monel	0619F	1019F	1619F	2519F

PN06					Diameter (mm)						Weight(Kg)	
DN	L(F4)	L(F5)	H	W	D	D1	D2	b	f	N-Ø	F4	F5
50	150	250	305	200	140	110	90	14	3.0	4-14	15	16
65	170	270	355	200	160	130	110	14	3.0	4-14	22	25
80	180	280	400	250	190	150	128	16	3.0	4-18	26	30
100	190	300	435	250	210	170	148	16	3.0	4-18	32	55
125	200	325	495	300	240	200	178	18	3.0	8-18	44	75
150	210	350	540	350	265	225	202	18	3.0	8-18	62	98
200	230	400	700	400	320	280	258	20	3.0	8-18	90	150
250	250	450	815	400	375	335	312	22	3.0	12-18	125	245
300	270	500	915	450	440	395	365	22	4.0	12-22	175	353
350	290	550	1190	450	495	445	415	22	4.0	12-22	250	490
400	310	600	1350	500	540	495	465	22	4.0	16-22	302	750
450	330	650	1680	500	595	550	520	22	4.0	16-22	405	985
500	350	700	1905	600	645	600	570	22	4.0	20-22	476	1063
600	390	800	2050	600	755	705	670	24	5.0	20-26	640	1390

PN10					Diameter (mm)						Weight(Kg)	
DN	L(F4)	L(F5)	H	W	D	D1	D2	b	f	N-Ø	F4	F5
50	150	250	305	200	165	125	102	18	3.0	4-18	15	16
65	170	270	355	200	185	145	122	18	3.0	8-18	22	25
80	180	280	400	250	200	160	138	20	3.0	8-18	26	30
100	190	300	435	250	220	180	158	20	3.0	8-18	32	55
125	200	325	495	300	250	210	188	22	3.0	8-18	44	75
150	210	350	540	350	285	240	212	22	3.0	8-22	62	98
200	230	400	700	400	340	295	268	24	3.0	8-22	95	150
250	250	450	815	400	395	350	320	26	3.0	12-22	128	245
300	270	500	915	450	445	400	370	26	4.0	12-22	180	353
350	290	550	1190	450	505	460	430	26	4.0	16-22	260	490
400	310	600	1350	500	565	515	482	28	4.0	16-26	310	750
450	330	650	1680	500	615	565	532	28	4.0	20-26	420	985
500	350	700	1905	600	670	620	585	28	4.0	20-26	490	1063
600	390	800	2050	600	780	725	685	28	5.0	20-30	660	1390

PN16					Diameter (mm)						Weight(Kg)	
DN	L(F4)	L(F5)	H	W	D	D1	D2	b	f	N-Ø	F4	F5
50	150	250	305	200	165	125	102	18	3.0	4-18	16	24
65	170	270	355	200	185	145	122	18	3.0	8-18	25	28
80	180	280	400	250	200	160	138	20	3.0	8-18	30	39
100	190	300	435	250	220	180	158	20	3.0	8-18	35	59
125	200	325	495	300	250	210	188	22	3.0	8-18	46	85
150	210	350	540	350	285	240	212	22	3.0	8-22	65	105
200	230	400	700	400	340	295	268	24	3.0	12-22	100	174
250	250	450	815	400	405	355	320	26	3.0	12-26	134	275
300	270	500	915	450	460	410	378	28	4.0	12-26	188	385
350	290	550	1190	450	520	470	438	30	4.0	16-26	275	510
400	310	600	1350	500	580	525	490	32	4.0	16-30	330	780
450	330	650	1680	500	640	585	550	34	4.0	20-30	435	1010
500	350	700	1905	600	715	650	610	36	4.0	20-33	505	1085
600	390	800	2050	600	840	770	725	40	5.0	20-36	670	1410

PN25					Diameter (mm)						Weight(Kg)	
DN	L(F4)	L(F5)	H	W	D	D1	D2	b	f	N-Ø	F4	F5
50	150	250	305	200	165	125	102	20	3.0	4-18	16	24
65	170	270	355	200	185	145	122	22	3.0	8-18	25	28
80	180	280	400	250	200	160	138	24	3.0	8-18	30	39
100	190	300	435	250	235	190	162	24	3.0	8-22	38	59
125	200	325	495	300	270	220	188	26	3.0	8-26	49	85
150	210	350	540	350	300	250	218	28	3.0	8-26	67	105
200	230	400	700	400	360	310	278	30	3.0	12-26	103	180
250	250	450	815	400	425	370	335	32	3.0	12-30	141	275
300	270	500	915	450	485	430	395	34	4.0	16-30	192	385
350	290	550	1190	450	555	490	450	38	4.0	16-33	282	547
400	310	600	1350	500	620	550	505	40	4.0	16-33	336	835
450	330	650	1680	500	670	600	555	46	4.0	20-36	444	1050
500	350	700	1905	600	730	660	615	48	4.0	20-36	512	1130
600	390	800	2050	600	845	770	720	48	5.0	20-39	685	1500

## DIN 3202-F7/F8(FACE-FACE)

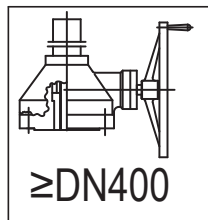
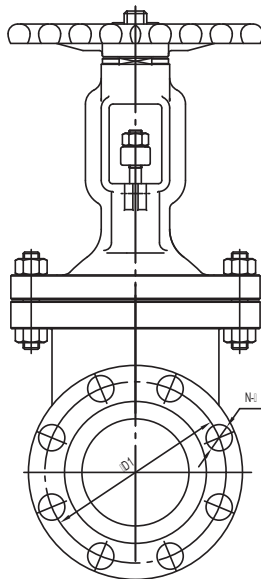
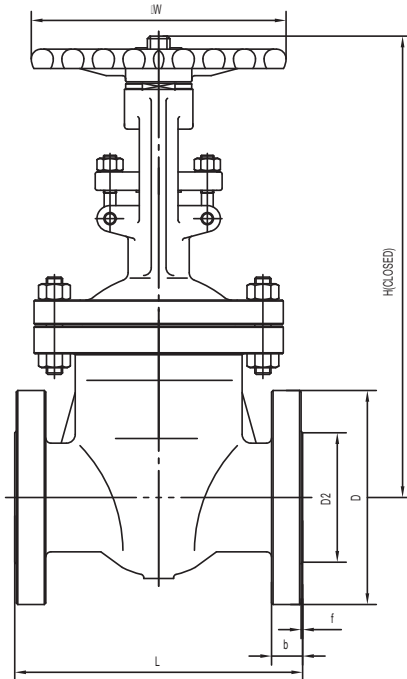

DPV Figure Numbers				
Material	DIN EN PN			
	PN40	PN63	PN100	PN160
Cast CS	4013F	6313F	10013F	16013F
Cast SS	4014F	6314F	10014F	16014F
Chrome Molys	4015F	6315F	10015F	16015F
Low Temp CS	4016F	6316F	10016F	16016F
Duplex	4017F	6317F	10017F	16017F
Super Duplex	4018F	6318F	10018F	16018F
Monel	4019F	6319F	10019F	16019F

PN40		Diameter (mm)									
DN	L(F7)	H	W	D	D1	D2	b	f	N-Ø	Weight(Kg)	
50	250	405	200	165	125	102	20	3.0	4-18	18	
65	290	455	280	185	145	122	22	3.0	8-18	32	
80	310	605	300	200	160	138	24	3.0	8-18	47	
100	350	655	350	235	190	162	24	3.0	8-22	60	
125	400	720	350	270	220	188	26	3.0	8-26	95	
150	450	780	400	300	250	218	28	3.0	8-26	130	
200	550	875	450	375	320	285	34	3.0	12-30	220	
250	650	1260	500	450	385	345	38	3.0	12-33	290	
300	750	1480	500	515	450	410	42	4.0	16-30	490	
350	850	1605	600	580	510	465	46	4.0	16-33	760	
400	950	1790	650	660	585	535	50	4.0	16-39	900	
450	1050	1955	700	685	610	560	57	4.0	20-39	1250	
500	1150	2170	700	755	670	615	57	4.0	20-42	1450	
600	1350	2600	800	890	795	735	72	5.0	20-48	1700	

PN63		Diameter (mm)									
DN	L(F7)	H	W	D	D1	D2	b	f	N-Ø	Weight(Kg)	
50	250	405	200	180	135	102	26	3.0	4-22	20	
65	290	455	280	205	160	122	26	3.0	8-22	35	
80	310	605	300	215	170	138	28	3.0	8-22	52	
100	350	655	350	250	200	162	30	3.0	8-26	66	
125	400	720	350	295	240	188	34	3.0	8-30	103	
150	450	780	400	345	280	218	36	3.0	8-33	140	
200	550	875	450	415	345	285	42	3.0	12-36	230	
250	650	1260	500	470	400	345	46	3.0	12-36	300	
300	750	1480	500	530	460	410	52	4.0	16-36	510	
350	850	1605	600	600	525	465	56	4.0	16-39	780	
400	950	1790	650	670	585	535	60	4.0	16-42	940	
450	*	*	*	*	*	*	*	*	*	*	
500	1150	2170	700	800	705	615	68	4.0	20-48	1600	
600	1350	2600	800	930	820	735	76	5.0	20-56	1850	

PN100		Diameter (mm)									
DN	L(F7)	H	W	D	D1	D2	b	f	N-Ø	Weight(Kg)	
50	250	425	280	195	145	102	30	3.0	4-26	46	
65	290	485	320	220	170	122	34	3.0	8-26	55	
80	310	510	350	230	180	138	36	3.0	8-26	72	
100	350	610	400	265	210	162	40	3.0	8-30	128	
125	400	700	450	315	250	188	40	3.0	8-33	180	
150	450	820	500	355	290	218	44	3.0	12-33	266	
200	550	920	600	430	360	285	52	3.0	12-36	419	
250	650	1080	650	505	430	345	60	3.0	12-39	730	
300	750	1220	650	585	500	410	68	4.0	16-42	850	
350	850	1475	*	655	560	465	74	4.0	16-48	1300	
400	950	1650	*	715	620	535	78	4.0	16-48	1750	
500	1150	2020	*	870	760	615	94	4.0	20-56	2050	

PN160		Diameter (mm)									
DN	L(F8)	H	W	D	D1	D2	b	f	N-Ø	Weight(Kg)	
50	300	425	280	195	145	102	30	3.0	4-26	59	
65	360	485	320	220	170	122	34	3.0	8-26	65	
80	390	510	350	230	180	138	36	3.0	8-26	85	
100	450	610	400	265	210	162	40	3.0	8-30	142	
125	525	700	450	315	250	188	44	3.0	8-33	215	
150	600	820	500	355	290	218	50	3.0	12-33	295	
200	750	920	600	430	360	285	60	3.0	12-36	440	
250	900	1080	650	505	430	345	68	3.0	12-39	790	
300	1050	1220	650	585	500	410	78	4.0	16-42	950	

# GLOBE VALVES



## GLOBE VALVE DESIGN FEATURES

- Flat Disc Design Standard
- Swivel Plug and Regulating Disc Available
- Outside Screw and Yoke
- Rising Stem
- Manual Operated, Actuation Available
- Bolted Bonnet Construction
- Design :EN 13709/DIN 3356
- Shell Thickness :EN 13709/DIN 3356
- Flanged :EN 1092-1/DIN2543-2547
- Face To Face :DIN 3202
- Testing :DIN 3230/EN 12266-1,2

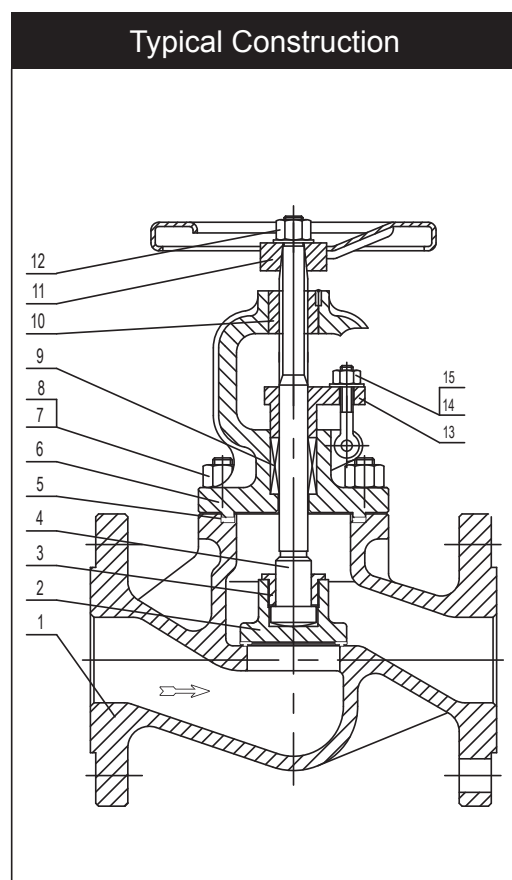

No.	Part Name
1	Body
2	Disc
3	Disc Nut
4	Stem
5	Gasket
6	Bonnet
7	Bolts
8	Nut
9	Packing
10	Yoke nut
11	Handwheel
12	Nut
13	Gland
14	Gland eyebolt
15	Nut

## STANDARD MATERIALS OF CONSTRUCTION

Part Name	EN 10213 Material Group					
	Carbon Steel	C-Mn Steel		C-Mo Steel	C-Cr-Mo Steel	
Material Name	GP240GH	G17Mn5	G20Mn5	G20Mo5	G17CrMo5-5	G17CrMo9-10
Material Number	1.0619	1.1131	1.6220	1.5419	1.7357	1.7379
Body/Bonnet	1.0619	1.1131	1.6220	1.5419	1.7357	1.7379
Wedge/Disc	The same as Body/Other materials available upon request					
Stem	1.4021/Materials available upon request					
Bolts/Nuts	B7(M)/2H(M)	L7(M)/7(M)		B16/4		
Gland Flange	The same as Body/Other materials available upon request					
Stem Nut	Austenitic Ductile Iron/Other materials available upon request					
Handwheel	Ductile /Malleable Iron					
Handwheel Nut	Carbon Steel					
Gland Bolts/Nuts	B7(M)/2H(M)	L7(M)/7(M)		B16/4		
Part Name	Corrosion Resistant Steel					
	GX5CrNi19-10	GX2CrNi19-11	GX5CrNi-Mo19-11-2	GX2CrNi-Mo19-11-2	GX5CrNi-Nb19-11	GX2NiCr-Mo28-20-2
Material Name	GX5CrNi19-10	GX2CrNi19-11	GX5CrNi-Mo19-11-2	GX2CrNi-Mo19-11-2	GX5CrNi-Nb19-11	GX2NiCr-Mo28-20-2
Material Number	1.4308	1.4309	1.4408	1.4409	1.4552	1.4458
Body/Bonnet	1.4308	1.4309	1.4408	1.4409	1.4552	1.4458
Wedge/Disc	The same to Body/Other materials available upon request					
Stem	1.4301	1.4306	1.4401	1.4404	1.4541	ALLOY 20
Bolts/Nuts	B8(M)/8(M)					
Gland Flange	The same as Body/Other materials available upon request					
Stem Nut	Austenitic Ductile Iron/Other materials available upon request					
Handwheel	Ductile /Malleable Iron					
Handwheel Nut	Carbon Steel					
Gland Bolts/Nuts	B8(M)/8(M)					

Note: Other materials available upon request

# GLOBE VALVES

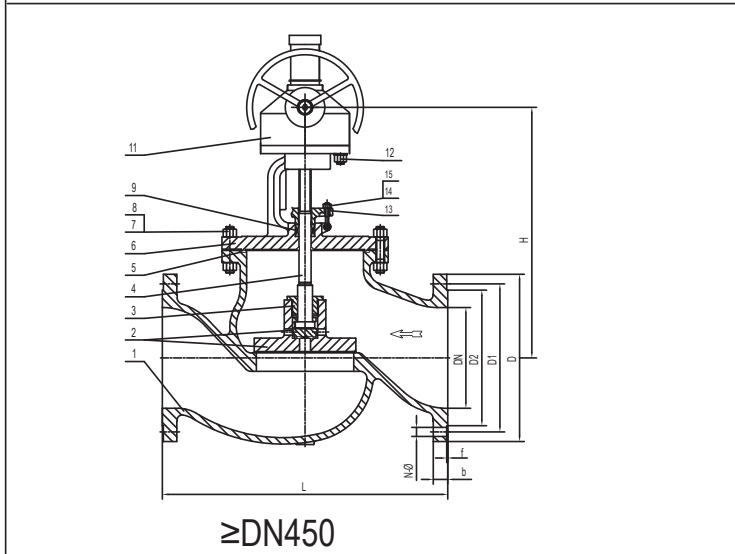
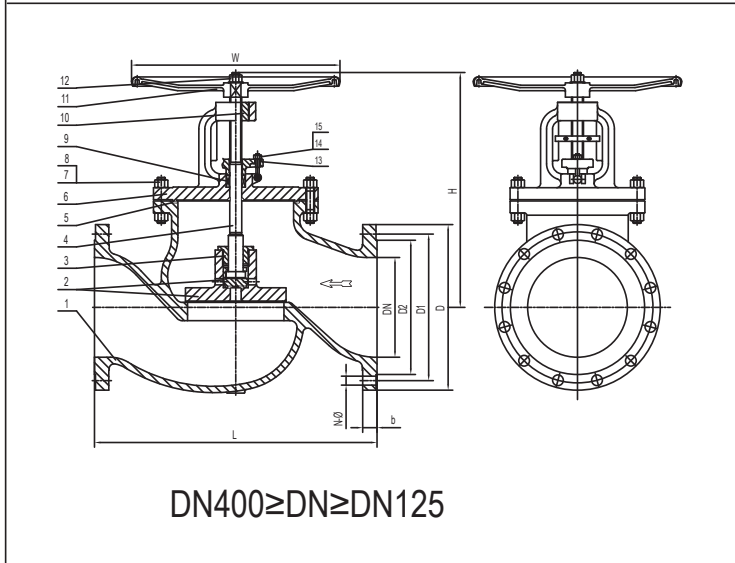
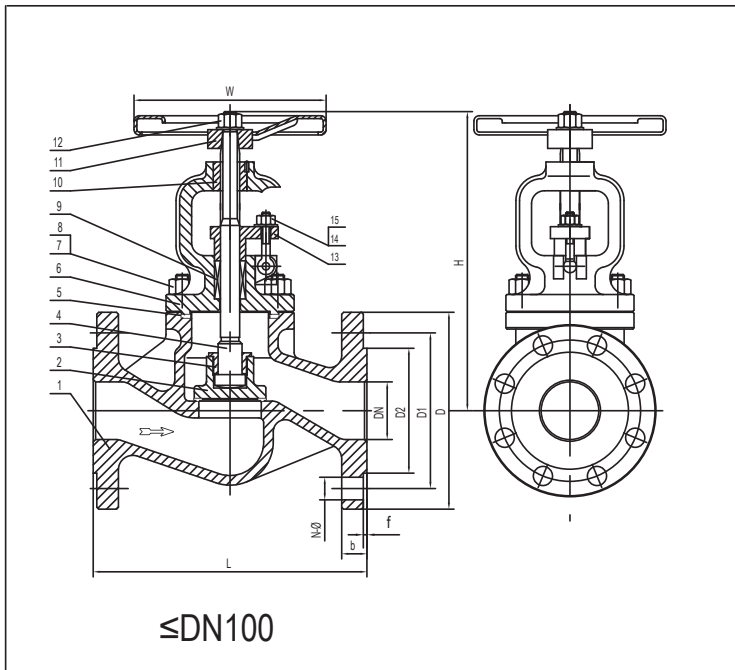

DPV Figure Numbers			
Material	DIN EN PN		
	PN06	PN10	PN16
Cast CS	0623F	1023F	1623F
Cast SS	0624F	1024F	1624F
Chrome Moly	0625F	1025F	1625F
Low Temp CS	0626F	1026F	1626F
Duplex	0627F	1027F	1627F
Super Duplex	0628F	1028F	1628F
Monel	0629F	1029F	1629F

PN06		Diameter (mm)									
DN	L(F1)	H	W	D	D1	D2	b	f	N-Ø	Weight(Kg)	
15	130	180	140	80	55	40	12	2.0	4-11	3.6	
20	150	190	140	90	65	50	14	2.0	4-11	5.2	
25	160	220	160	100	75	60	14	2.0	4-11	6.8	
32	180	220	160	120	90	70	14	2.0	4-14	8.5	
40	200	255	180	130	100	80	14	3.0	4-14	11.7	
50	230	260	180	140	110	90	14	3.0	4-14	16.0	
65	290	265	200	160	130	110	14	3.0	4-14	22.8	
80	310	300	250	190	150	128	16	3.0	4-18	31.0	
100	350	310	300	210	170	148	16	3.0	4-18	38.4	
125	400	390	300	240	200	178	18	3.0	8-18	58	
150	480	410	400	265	225	202	18	3.0	8-18	82	
200	600	495	400	320	280	258	20	3.0	8-18	167	
250	730	660	450	375	335	312	22	3.0	12-18	314	
300	850	705	500	440	395	365	22	4.0	12-22	430	
350	980	850	550	495	445	415	22	4.0	12-22	590	
400	1100	950	600	540	495	465	22	4.0	16-22	954	
450	*	*	*	595	550	520	22	4.0	16-22	*	
500	1250	*	*	645	600	570	22	4.0	20-22	*	
600	1450	*	*	755	705	670	24	5.0	20-26	*	

PN10		Diameter (mm)									
DN	L(F1)	H	W	D	D1	D2	b	f	N-Ø	Weight(Kg)	
15	130	180	140	95	65	45	16	2.0	4-14	3.6	
20	150	190	140	105	75	58	18	2.0	4-14	5.2	
25	160	220	160	115	85	68	18	2.0	4-14	6.8	
32	180	220	160	140	100	78	18	2.0	4-18	8.5	
40	200	255	180	150	110	88	18	3.0	4-18	11.7	
50	230	260	180	165	125	102	18	3.0	4-18	16.0	
65	290	265	200	185	145	122	18	3.0	8-18	22.8	
80	310	300	250	200	160	138	20	3.0	8-18	31.0	
100	350	310	300	220	180	158	20	3.0	8-18	38.4	
125	400	390	300	250	210	188	22	3.0	8-18	58	
150	480	410	400	285	240	212	22	3.0	8-22	82	
200	600	495	400	340	295	268	24	3.0	8-22	167	
250	730	660	450	395	350	320	26	3.0	12-22	314	
300	850	705	500	445	400	370	26	4.0	12-22	430	
350	980	850	550	505	460	430	26	4.0	16-22	590	
400	1100	950	600	565	515	482	28	4.0	16-26	954	
450	*	*	*	615	565	532	28	4.0	20-26	*	
500	1250	*	*	670	620	585	28	4.0	20-26	*	
600	1450	*	*	780	725	685	28	5.0	20-30	*	

PN16		Diameter (mm)									
DN	L(F1)	H	W	D	D1	D2	b	f	N-Ø	Weight(Kg)	
15	130	180	140	95	65	45	16	2.0	4-14	3.6	
20	150	190	140	105	75	58	18	2.0	4-14	5.2	
25	160	220	160	115	85	68	18	2.0	4-14	6.8	
32	180	220	160	140	100	78	18	2.0	4-18	8.5	
40	200	255	180	150	110	88	18	3.0	4-18	11.7	
50	230	260	180	165	125	102	18	3.0	4-18	16.0	
65	290	265	200	185	145	122	18	3.0	8-18	22.8	
80	310	300	250	200	160	138	20	3.0	8-18	31.0	
100	350	310	300	220	180	158	20	3.0	8-18	38.4	
125	400	390	300	250	210	188	22	3.0	8-18	58	
150	480	410	400	285	240	212	22	3.0	8-22	82	
200	600	495	400	340	295	268	24	3.0	12-22	167	
250	730	660	450	405	355	320	26	3.0	12-26	314	
300	850	705	500	460	410	378	28	4.0	12-26	430	
350	980	850	550	520	470	438	30	4.0	16-26	590	
400	1100	950	600	580	525	490	32	4.0	16-30	954	
450	*	*	*	640	585	550	34	4.0	20-30	*	
500	1250	*	*	715	650	610	36	4.0	20-33	*	
600	1450	*	*	840	770	725	40	5.0	20-36	*	

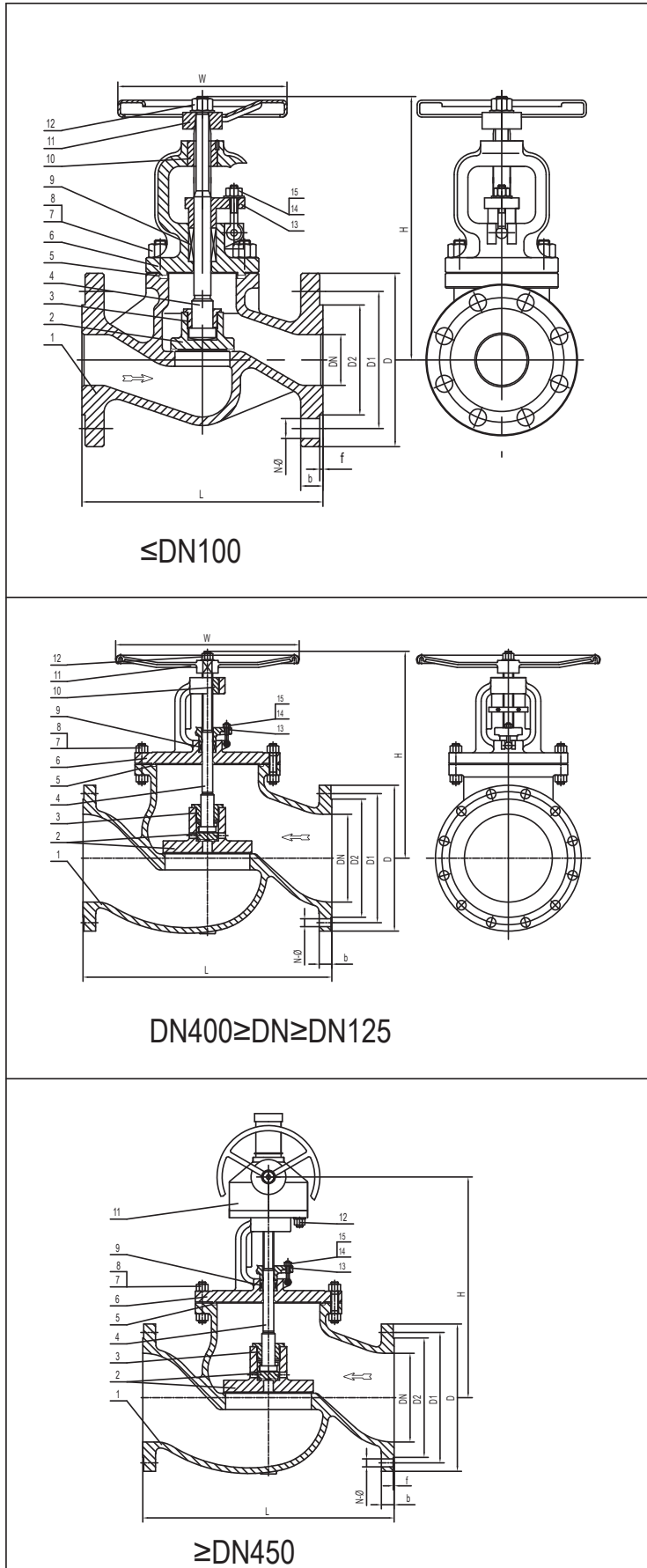

DPV Figure Numbers				
Material	DIN EN PN			
	PN25	PN40	PN63	
Cast CS	2523F	4023F	6323F	
Cast SS	2524F	4024F	6324F	
Chrome Molys	2525F	4025F	6325F	
Low Temp CS	2526F	4026F	6326F	
Duplex	2527F	4027F	6327F	
Super Duplex	2528F	4028F	6328F	
Monel	2529F	4029F	6329F	

PN25		Diameter (mm)									
DN	L(F1)	H	W	D	D1	D2	b	f	N-Ø	Weight(Kg)	
15	130	180	140	95	65	45	16	2.0	4-14	3.6	
20	150	190	140	105	75	58	18	2.0	4-14	5.2	
25	160	220	160	115	85	68	18	2.0	4-14	6.8	
32	180	220	160	140	100	78	18	2.0	4-18	8.5	
40	200	255	180	150	110	88	18	3.0	4-18	11.7	
50	230	260	180	165	125	102	20	3.0	4-18	16.0	
65	290	265	200	185	145	122	22	3.0	8-18	23.3	
80	310	300	250	200	160	138	24	3.0	8-18	32.6	
100	350	310	300	235	190	162	24	3.0	8-22	41.4	
125	400	390	300	270	220	188	26	3.0	8-26	62.7	
150	480	410	400	300	250	218	28	3.0	8-26	88.2	
200	600	495	400	360	310	278	30	3.0	12-26	177	
250	730	660	450	425	370	335	32	3.0	12-30	329	
300	850	705	500	485	430	395	34	4.0	16-30	450	
350	980	850	550	555	490	450	38	4.0	16-33	624	
400	1100	950	600	620	550	505	40	4.0	16-33	999	
450	*	*	*	670	600	555	46	4.0	20-36	*	
500	1250	*	*	730	660	615	48	4.0	20-36	*	
600	1450	*	*	845	770	720	48	5.0	20-39	*	

PN40		Diameter (mm)									
DN	L(F1)	H	W	D	D1	D2	b	f	N-Ø	Weight(Kg)	
15	130	180	140	95	65	45	16	2.0	4-14	3.6	
20	150	190	140	105	75	58	18	2.0	4-14	5.2	
25	160	220	160	115	85	68	18	2.0	4-14	6.8	
32	180	220	160	140	100	78	18	2.0	4-18	8.5	
40	200	255	180	150	110	88	18	3.0	4-18	11.7	
50	230	260	180	165	125	102	20	3.0	4-18	16.0	
65	290	265	200	185	145	122	22	3.0	8-18	23.6	
80	310	300	250	200	160	138	24	3.0	8-18	33.4	
100	350	310	300	235	190	162	24	3.0	8-22	42.4	
125	400	390	300	270	220	188	26	3.0	8-26	64.2	
150	480	410	400	300	250	218	28	3.0	8-26	91	
200	600	495	400	375	320	285	34	3.0	12-30	187	
250	730	660	450	450	385	345	38	3.0	12-33	340	
300	850	705	500	515	450	410	42	4.0	16-30	484	
350	980	850	550	580	510	465	46	4.0	16-33	672	
400	1100	950	600	660	585	535	50	4.0	16-39	1025	
450	*	*	*	685	610	560	57	4.0	20-39	*	
500	1250	*	*	755	670	615	57	4.0	20-42	*	
600	1450	*	*	890	795	735	72	5.0	20-48	*	

PN63		Diameter (mm)									
DN	L(F2)	H	W	D	D1	D2	b	f	N-Ø	Weight(Kg)	
15	210	240	140	105	75	45	20	2.0	4-14	8	
20	230	260	140	130	90	58	22	2.0	4-18	10	
25	230	275	160	140	100	68	24	2.0	4-18	12	
32	260	285	160	155	110	78	26	2.0	4-22	16	
40	260	300	180	170	125	88	28	3.0	4-22	17	
50	300	305	200	180	135	102	26	3.0	4-22	20	
65	340	355	200	205	160	122	26	3.0	8-22	30	
80	380	400	250	215	170	138	28	3.0	8-22	38	
100	430	435	250	250	200	162	30	3.0	8-26	56	
125	500	500	300	295	240	188	34	3.0	8-30	75	
150	550	540	350	345	280	218	36	3.0	8-33	100	
200	650	700	400	415	345	285	42	3.0	12-36	182	
250	775	815	450	470	400	345	46	3.0	12-36	278	
300	900	915	500	530	460	410	52	4.0	16-36	398	
350	1025	1190	550	600	525	465	56	4.0	16-39	500	
400	1150	1350	600	670	585	535	60	4.0	16-42	618	
450	*	*	*	*	*	*	*	*	*	*	
500	1400	*	*	800	705	615	68	4.0	20-48	*	
600	1600	*	*	930	820	735	76	5.0	20-56	*	

# GLOBE VALVES

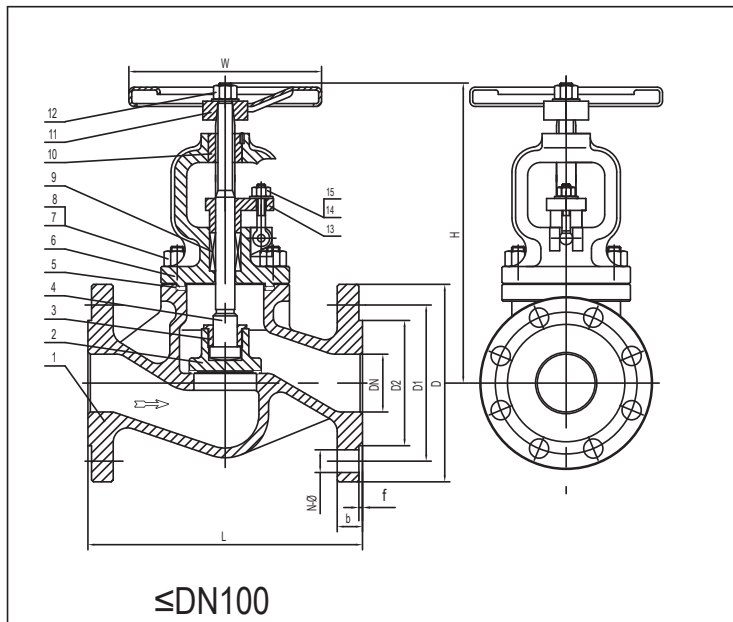

≤DN100

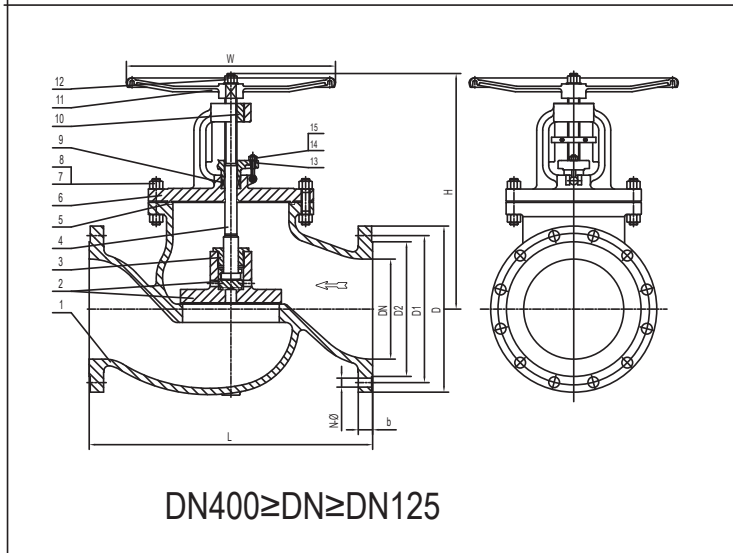

DN400 ≥ DN ≥ DN125

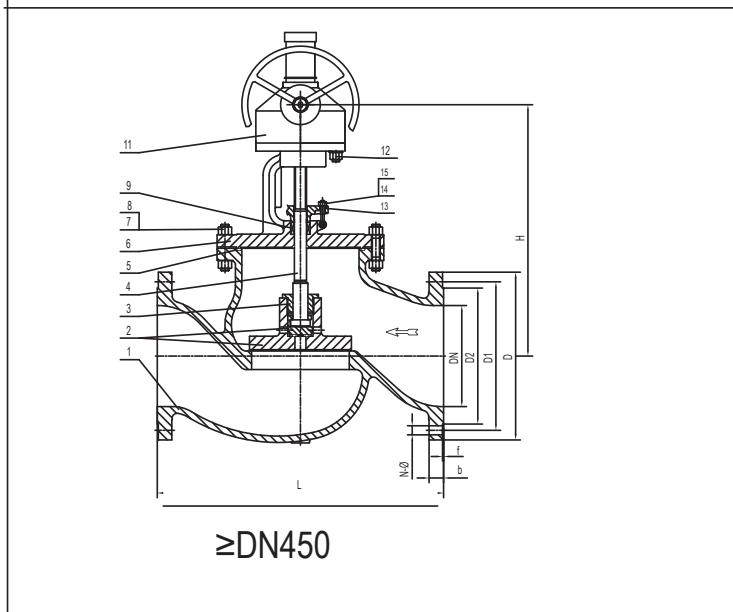

≥DN450

DPV Figure Numbers		
Material	DIN EN PN	
	PN100	PN160
Cast CS	10023F	16023F
Cast SS	10024F	16024F
Chrome Molys	10025F	16025F
Low Temp CS	10026F	16026F
Duplex	10027F	16027F
Super Duplex	10028F	16028F
Monel	10029F	16029F

PN100		Diameter (mm)								
DN	L(F2)	H	W	D	D1	D2	b	f	N-Ø	Weight(Kg)
15	210	240	140	105	75	45	20	2.0	4-14	*
20	230	260	140	130	90	58	22	2.0	4-18	*
25	230	275	160	140	100	68	24	2.0	4-18	*
32	260	285	160	155	110	78	26	2.0	4-22	*
40	260	300	180	170	125	88	28	3.0	4-22	*
50	300	325	200	195	145	102	30	3.0	4-26	*
65	340	365	200	220	170	122	34	3.0	8-26	*
80	380	415	250	230	180	138	36	3.0	8-26	*
100	430	455	250	265	210	162	40	3.0	8-30	*
125	500	505	300	315	250	188	40	3.0	8-33	*
150	550	555	350	355	290	218	44	3.0	12-33	*
200	650	745	400	430	360	285	52	3.0	12-36	*
250	775	865	450	505	430	345	60	3.0	12-39	*
300	900	950	500	585	500	410	68	4.0	16-42	*
350	1025	1270	550	655	560	465	74	4.0	16-48	*
400	1150	1450	600	715	620	535	78	4.0	16-48	*

PN160		Diameter (mm)								
DN	L(F2)	H	W	D	D1	D2	b	f	N-Ø	Weight(Kg)
15	210	240	140	105	75	45	20	2.0	4-14	*
20	230	260	140	130	90	58	22	2.0	4-18	*
25	230	275	160	140	100	68	24	2.0	4-18	*
32	260	285	160	155	110	78	26	2.0	4-22	*
40	260	300	180	170	125	88	28	3.0	4-22	*
50	300	325	200	195	145	102	30	3.0	4-26	*
65	340	370	200	195	145	102	30	3.0	4-26	*
80	380	430	250	220	170	122	34	3.0	8-26	*
100	430	480	250	230	180	138	36	3.0	8-26	*
125	500	530	300	265	210	162	40	3.0	8-30	*
150	550	590	350	315	250	188	44	3.0	8-33	*
200	650	785	400	355	290	218	50	3.0	12-33	*
250	775	890	450	430	360	285	60	3.0	12-36	*
300	900	965	500	505	430	345	68	3.0	12-39	*
350	1025	1285	550	585	500	410	78	4.0	16-42	*

NOTE: DN < 50; PN > 40; VALVES IN FORGED STEEL



# PISTON CHECK VALVES

## PISTON CHECK VALVE DESIGN FEATURES

- Piston Disc Design
- Regular Opening Type
- Bolted Cover Construction
- Spring Design Standard
- Design :EN 13709/DIN 3356
- Shell Thickness :EN 13709/DIN 3356
- Flanged :EN 1092-1/DIN2543-2547
- Face To Face :DIN 3202
- Testing :DIN 3230/EN 12266-1,2

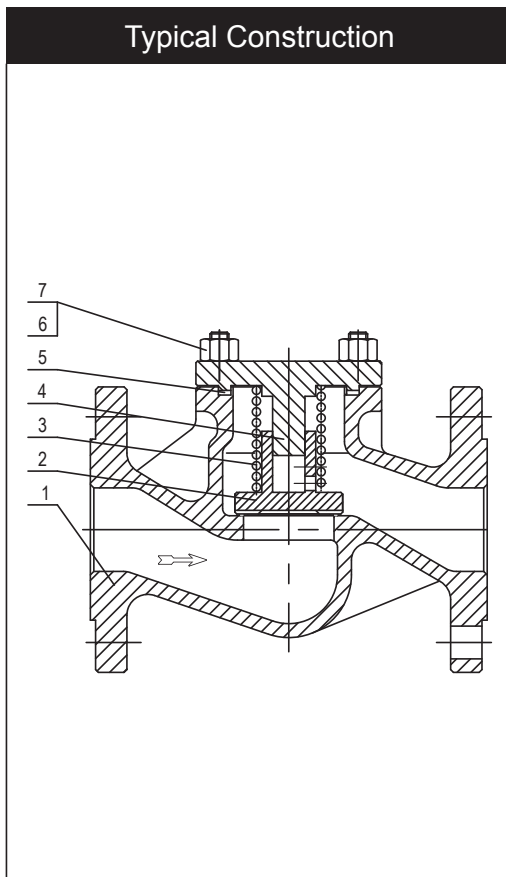

No.	Part Name
1	Body
2	Disc
3	Spring
4	Cover
5	Gasket
6	Bolts
7	Nut



# PISTON CHECK VALVES



## STANDARD MATERIALS OF CONSTRUCTION

Part Name	EN 10213 Material Group					
	Carbon Steel	C-Mn Steel		C-Mo Steel	C-Cr-Mo Steel	
Material Name	GP240GH	G17Mn5	G20Mn5	G20Mo5	G17CrMo5-5	G17CrMo9-10
Material Number	1.0619	1.1131	1.6220	1.5419	1.7357	1.7379
Body/Bonnet	1.0619	1.1131	1.6220	1.5419	1.7357	1.7379
Wedge/Disc	The same as Body/Other materials available upon request					
Spring	1.4401/Materials available upon request					
Bolts/Nuts	B7(M)/2H(M)	L7(M)/7(M)		B16/4		
Part Name	Corrosion Resistant Steel					
	GX5CrNi19-10	GX2CrNi19-11	GX5CrNi-Mo19-11-2	GX2CrNi-Mo19-11-2	GX5CrNi-Nb19-11	GX2NiCr-Mo28-20-2
Material Name	GX5CrNi19-10	GX2CrNi19-11	GX5CrNi-Mo19-11-2	GX2CrNi-Mo19-11-2	GX5CrNi-Nb19-11	GX2NiCr-Mo28-20-2
Material Number	1.4308	1.4309	1.4408	1.4409	1.4552	1.4458
Body/Bonnet	1.4308	1.4309	1.4408	1.4409	1.4552	1.4458
Wedge/Disc	The same as Body/Other materials available upon request					
Spring	1.4301	1.4306	1.4401	1.4404	1.4541	ALLOY 20
Bolts/Nuts	B8(M)/8(M)					

Note: Other materials available upon request

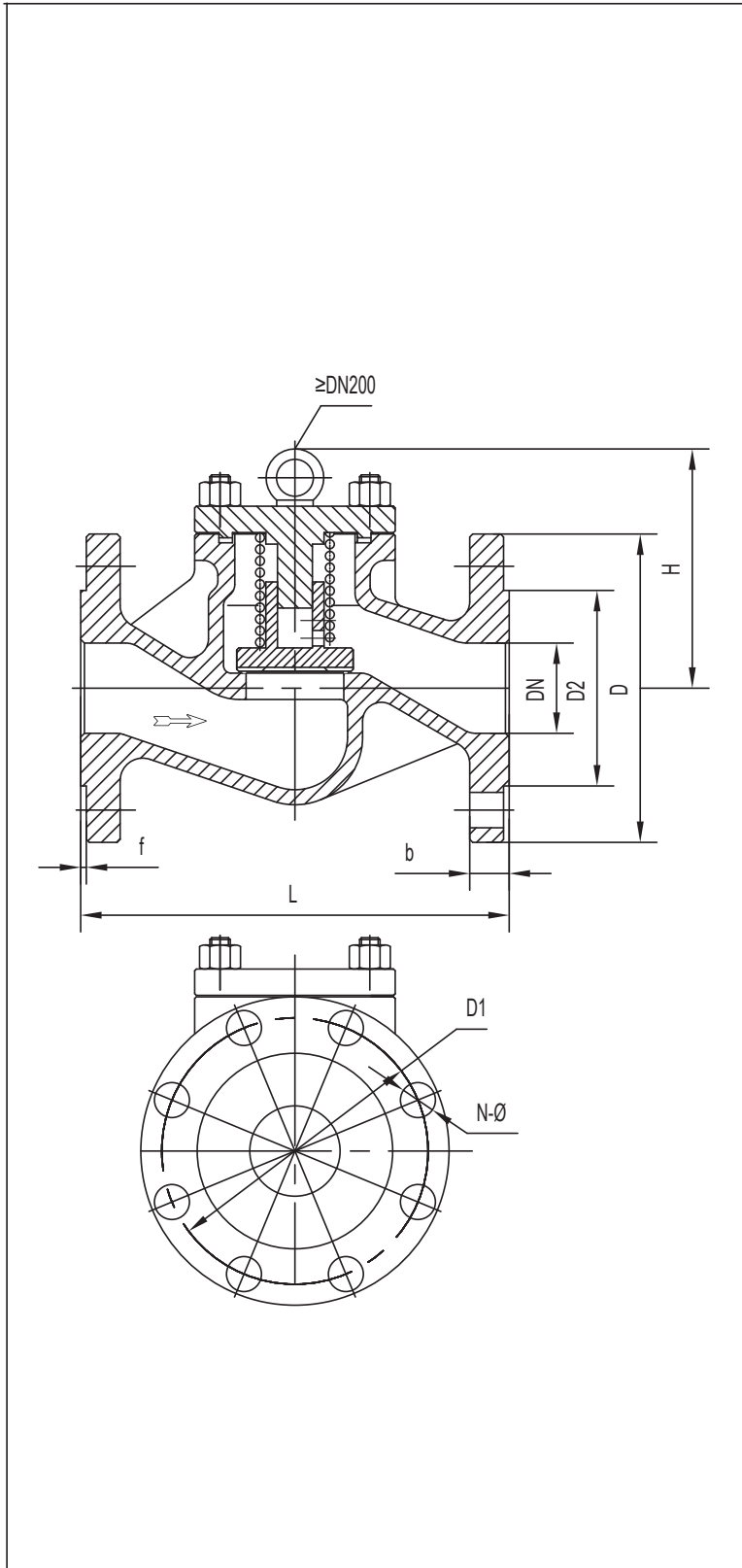

DPV Figure Numbers			
Material	DIN EN PN		
	PN06	PN10	PN16
Cast CS	0623F	1023F	1623F
Cast SS	0624F	1024F	1624F
Chrome Moly	0625F	1025F	1625F
Low Temp CS	0626F	1026F	1626F
Duplex	0627F	1027F	1627F
Super Duplex	0628F	1028F	1628F
Monel	0629F	1029F	1629F

PN06		Diameter (mm)							
DN	L	H	D	D1	D2	b	f	N-Ø	Weight(Kg)
15	130	60	80	55	40	12	2.0	4-11	3.4
20	150	65	90	65	50	14	2.0	4-11	3.9
25	160	75	100	75	60	14	2.0	4-11	4.6
32	180	78	120	90	70	14	2.0	4-14	6.4
40	200	85	130	100	80	14	3.0	4-14	8.2
50	230	90	140	110	90	14	3.0	4-14	10.8
65	290	105	160	130	110	14	3.0	4-14	16.3
80	310	125	190	150	128	16	3.0	4-18	22.5
100	350	145	210	170	148	16	3.0	4-18	32.0
125	400	173	240	200	178	18	3.0	8-18	51
150	480	208	265	225	202	18	3.0	8-18	74
200	600	370	320	280	258	20	3.0	8-18	139
250	730	460	375	335	312	22	3.0	12-18	208
300	850	505	440	395	365	22	4.0	12-22	308
350	980	555	495	445	415	22	4.0	12-22	520
400	1100	635	540	495	465	22	4.0	16-22	820

PN10		Diameter (mm)							
DN	L	H	D	D1	D2	b	f	N-Ø	Weight(Kg)
15	130	60	95	65	45	16	2.0	4-14	3.4
20	150	65	105	75	58	18	2.0	4-14	3.9
25	160	75	115	85	68	18	2.0	4-14	4.6
32	180	78	140	100	78	18	2.0	4-18	6.4
40	200	85	150	110	88	18	3.0	4-18	8.2
50	230	90	165	125	102	18	3.0	4-18	10.8
65	290	105	185	145	122	18	3.0	8-18	16.3
80	310	125	200	160	138	20	3.0	8-18	22.5
100	350	145	220	180	158	20	3.0	8-18	32
125	400	173	250	210	188	22	3.0	8-18	51
150	480	208	285	240	212	22	3.0	8-22	74
200	600	370	340	295	268	24	3.0	8-22	139
250	730	460	395	350	320	26	3.0	12-22	208
300	850	505	445	400	370	26	4.0	12-22	308
350	980	555	505	460	430	26	4.0	16-22	520
400	1100	635	565	515	482	28	4.0	16-26	820

PN16		Diameter (mm)							
DN	L	H	D	D1	D2	b	f	N-Ø	Weight(Kg)
15	130	60	95	65	45	16	2.0	4-14	3.4
20	150	65	105	75	58	18	2.0	4-14	3.9
25	160	75	115	85	68	18	2.0	4-14	4.6
32	180	78	140	100	78	18	2.0	4-18	6.4
40	200	85	150	110	88	18	3.0	4-18	8.2
50	230	90	165	125	102	18	3.0	4-18	10.8
65	290	105	185	145	122	18	3.0	8-18	16.3
80	310	125	200	160	138	20	3.0	8-18	22.5
100	350	145	220	180	158	20	3.0	8-18	32.0
125	400	173	250	210	188	22	3.0	8-18	51
150	480	208	285	240	212	22	3.0	8-22	74
200	600	370	340	295	268	24	3.0	12-22	139
250	730	460	405	355	320	26	3.0	12-26	208
300	850	505	460	410	378	28	4.0	12-26	308
350	980	555	520	470	438	30	4.0	16-26	520
400	1100	635	580	525	490	32	4.0	16-30	820

# PISTON CHECK VALVES

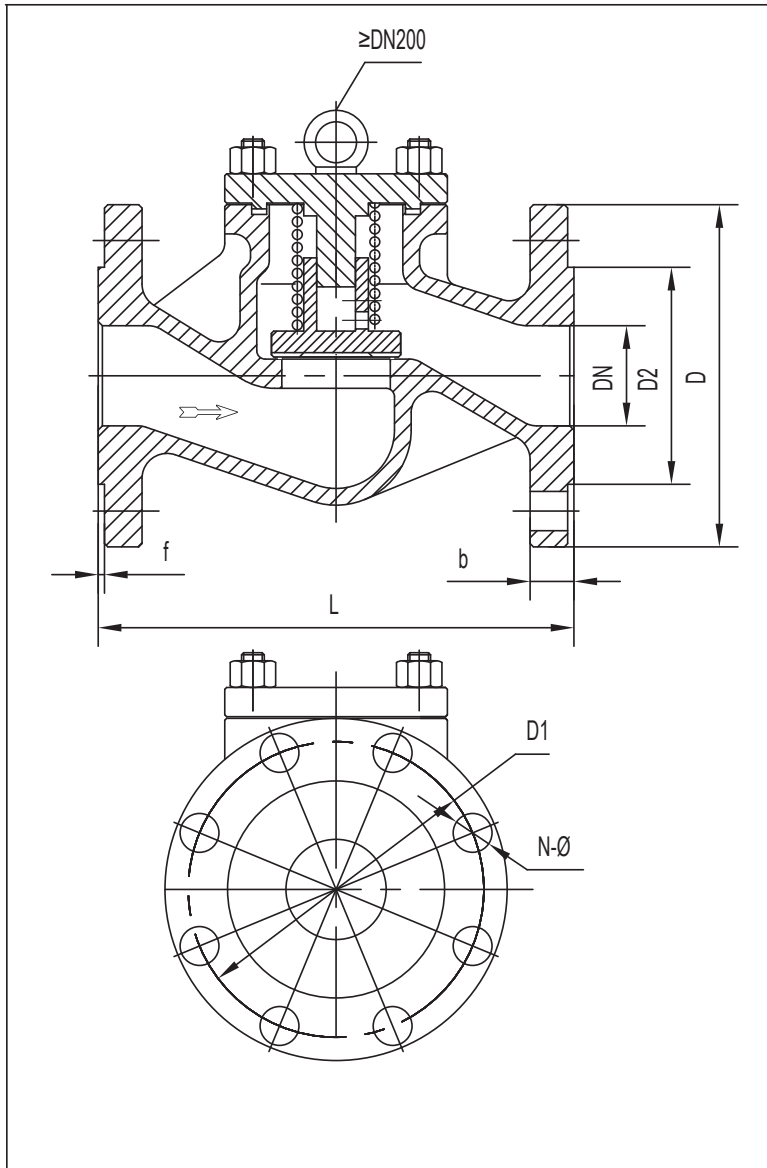

DPV Figure Numbers		
Material	DIN EN PN	
	PN25	PN40
Cast CS	2523F	4023F
Cast SS	2524F	4024F
Chrome Molys	2525F	4025F
Low Temp CS	2526F	4026F
Duplex	2527F	4027F
Super Duplex	2528F	4028F
Monel	2529F	4029F

PN25									
Diameter (mm)									
DN	L	H	D	D1	D2	b	f	N-Ø	Weight(Kg)
15	130	60	95	65	45	16	2.0	4-14	3.4
20	150	65	105	75	58	18	2.0	4-14	3.9
25	160	75	115	85	68	18	2.0	4-14	4.6
32	180	78	140	100	78	18	2.0	4-18	6.4
40	200	85	150	110	88	18	3.0	4-18	8.2
50	230	90	165	125	102	20	3.0	4-18	10.8
65	290	105	185	145	122	22	3.0	8-18	16.9
80	310	125	200	160	138	24	3.0	8-18	24.1
100	350	145	235	190	162	24	3.0	8-22	35.0
125	400	173	270	220	188	26	3.0	8-26	55.7
150	480	208	300	250	218	28	3.0	8-26	80.2
200	600	370	360	310	278	30	3.0	12-26	149
250	730	460	425	370	335	32	3.0	12-30	223
300	850	505	485	430	395	34	4.0	16-30	328
350	980	555	555	490	450	38	4.0	16-33	554
400	1100	635	620	550	505	40	4.0	16-33	865
PN40									
Diameter (mm)									
DN	L	H	D	D1	D2	b	f	N-Ø	Weight(Kg)
15	130	60	95	65	45	16	2.0	4-14	3.4
20	150	65	105	75	58	18	2.0	4-14	3.9
25	160	75	115	85	68	18	2.0	4-14	4.6
32	180	78	140	100	78	18	2.0	4-18	6.4
40	200	85	150	110	88	18	3.0	4-18	8.2
50	230	90	165	125	102	20	3.0	4-18	10.8
65	290	105	185	145	122	22	3.0	8-18	16.9
80	310	125	200	160	138	24	3.0	8-18	24.1
100	350	145	235	190	162	24	3.0	8-22	35.0
125	400	173	270	220	188	26	3.0	8-26	55.7
150	480	208	300	250	218	28	3.0	8-26	80.2
200	600	370	375	320	285	34	3.0	12-30	157
250	730	460	450	385	345	38	3.0	12-33	240
300	850	505	515	450	410	42	4.0	16-30	356
350	980	555	580	510	465	46	4.0	16-33	587
400	1100	635	660	585	535	50	4.0	16-39	927

## SWING CHECK VALVE DESIGN FEATURES

- Swing Disc Design
- Regular Opening Type
- Bolted Cover Construction
- Outside Pin Design Standard
- Design :EN 13709/DIN 3356
- Shell Thickness :EN 13709/DIN 3356
- Flanged :EN 1092-1/DIN2543-2547
- Face To Face :DIN 3202
- Testing :DIN 3230/EN 12266-1,2

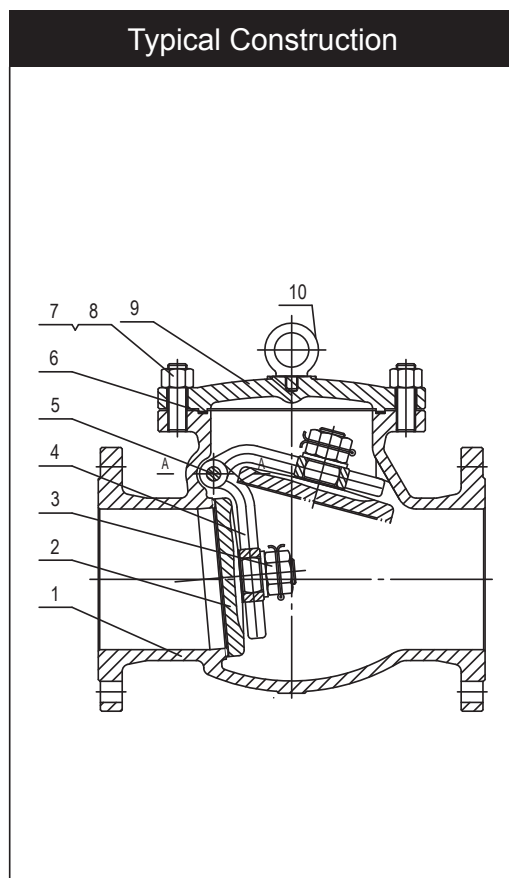

No.	Part Name
1	Body
2	Disc
3	Disc Nut
4	Arm
5	Hinge Pin
6	Gasket
7	Bolts
8	Nut
9	Cover
10	Hook Screw

# SWING CHECK VALVES



## STANDARD MATERIALS OF CONSTRUCTION

Part Name	EN 10213 Material Group					
	Carbon Steel	C-Mn Steel		C-Mo Steel	C-Cr-Mo Steel	
Material Name	GP240GH	G17Mn5	G20Mn5	G20Mo5	G17CrMo5-5	G17CrMo9-10
Material Number	1.0619	1.1131	1.6220	1.5419	1.7357	1.7379
Body/Bonnet	1.0619	1.1131	1.6220	1.5419	1.7357	1.7379
Wedge/Disc	The same as Body/Other materials available upon request					
Hinge Pin	1.4021/Materials available upon request					
Bolts/Nuts	B7(M)/2H(M)	L7(M)/7(M)		B16/4		
Part Name	Corrosion Resistant Steel					
Material Name	GX5CrNi19-10	GX2CrNi19-11	GX5CrNi-Mo19-11-2	GX2CrNi-Mo19-11-2	GX5CrNi-Nb19-11	GX2NiCr-Mo28-20-2
Material Number	1.4308	1.4309	1.4408	1.4409	1.4552	1.4458
Body/Bonnet	1.4308	1.4309	1.4408	1.4409	1.4552	1.4458
Wedge/Disc	The same as Body/Other materials available upon request					
Hinge Pin	1.4301	1.4306	1.4401	1.4404	1.4541	ALLOY 20
Bolts/Nuts	B8(M)/8(M)					

Note: Other materials available upon request



# SWING CHECK VALVES

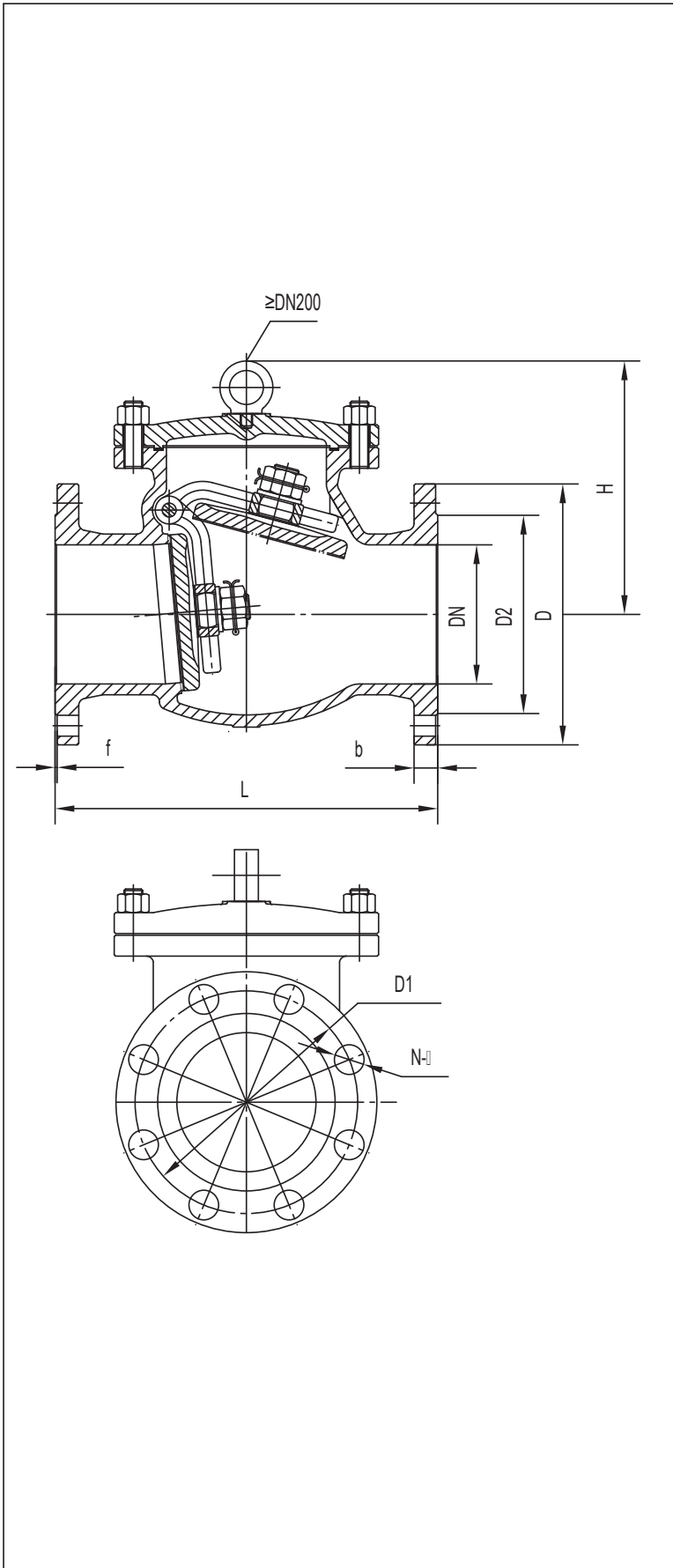

DPV Figure Numbers									
Material	DIN EN PN								
	PN06	PN10	PN16	PN25					
Cast CS	0623F	1023F	1623F	2523F					
Cast SS	0624F	1024F	1624F	2524F					
Chrome Moly	0625F	1025F	1625F	2525F					
Low Temp CS	0626F	1026F	1626F	2526F					
Duplex	0627F	1027F	1627F	2527F					
Super Duplex	0628F	1028F	1628F	2528F					
Monel	0629F	1029F	1629F	2529F					

PN06		Diameter (mm)							
DN	L	H	D	D1	D2	b	f	N-Ø	Weight(Kg)
50	230	135	140	110	90	14	3.0	4-14	17
65	290	145	160	130	110	14	3.0	4-14	24
80	310	165	190	150	128	16	3.0	4-18	29
100	350	180	210	170	148	16	3.0	4-18	48
125	400	210	240	200	178	18	3.0	8-18	60
150	480	233	265	225	202	18	3.0	8-18	80
200	600	305	320	280	258	20	3.0	8-18	125
250	730	350	375	335	312	22	3.0	12-18	*
300	850	390	440	395	365	22	4.0	12-22	*
350	980	430	495	445	415	22	4.0	12-22	*
400	1100	470	540	495	465	22	4.0	16-22	*
450	*	*	595	550	520	22	4.0	16-22	*
500	1250	525	645	600	570	22	4.0	20-22	*
600	1450	560	755	705	670	24	5.0	20-26	*

PN10		Diameter (mm)							
DN	L	H	D	D1	D2	b	f	N-Ø	Weight(Kg)
50	230	135	165	125	102	18	3.0	4-18	17
65	290	145	185	145	122	18	3.0	8-18	24
80	310	165	200	160	138	20	3.0	8-18	29
100	350	180	220	180	158	20	3.0	8-18	48
125	400	210	250	210	188	22	3.0	8-18	60
150	480	233	285	240	212	22	3.0	8-22	80
200	600	305	340	295	268	24	3.0	8-22	125
250	730	350	395	350	320	26	3.0	12-22	*
300	850	390	445	400	370	26	4.0	12-22	*
350	980	430	505	460	430	26	4.0	16-22	*
400	1100	470	565	515	482	28	4.0	16-26	*
450	*	*	615	565	532	28	4.0	20-26	*
500	1250	525	670	620	585	28	4.0	20-26	*
600	1450	560	780	725	685	28	5.0	20-30	*

  

PN16		Diameter (mm)							
DN	L	H	D	D1	D2	b	f	N-Ø	Weight(Kg)
50	230	135	165	125	102	18	3.0	4-18	17
65	290	145	185	145	122	18	3.0	8-18	24
80	310	165	200	160	138	20	3.0	8-18	29
100	350	180	220	180	158	20	3.0	8-18	48
125	400	210	250	210	188	22	3.0	8-18	60
150	480	233	285	240	212	22	3.0	8-22	80
200	600	305	340	295	268	24	3.0	12-22	125
250	730	350	405	355	320	26	3.0	12-26	*
300	850	390	460	410	378	28	4.0	12-26	*
350	980	430	520	470	438	30	4.0	16-26	*
400	1100	470	580	525	490	32	4.0	16-30	*
450	*	*	640	585	550	34	4.0	20-30	*
500	1250	525	715	650	610	36	4.0	20-33	*
600	1450	560	840	770	725	40	5.0	20-36	*

PN25		Diameter (mm)							
DN	L	H	D	D1	D2	b	f	N-Ø	Weight(Kg)
50	230	160	165	125	102	20	3.0	4-18	17
65	290	175	185	145	122	22	3.0	8-18	24
80	310	185	200	160	138	24	3.0	8-18	29
100	350	220	235	190	162	24	3.0	8-22	48
125	400	250	270	220	188	26	3.0	8-26	60
150	480	276	300	250	218	28	3.0	8-26	80
200	600	350	360	310	278	30	3.0	12-26	125
250	730	410	425	370	335	32	3.0	12-30	*
300	850	430	485	430	395	34	4.0	16-30	*
350	980	520	555	490	450	38	4.0	16-33	*
400	1100	560	620	550	505	40	4.0	16-33	*
450	*	*	670	600	555	46	4.0	20-36	*
500	1250	620	730	660	615	48	4.0	20-36	*
600	1450	690	845	770	720	48	5.0	20-39	*

# SWING CHECK VALVES

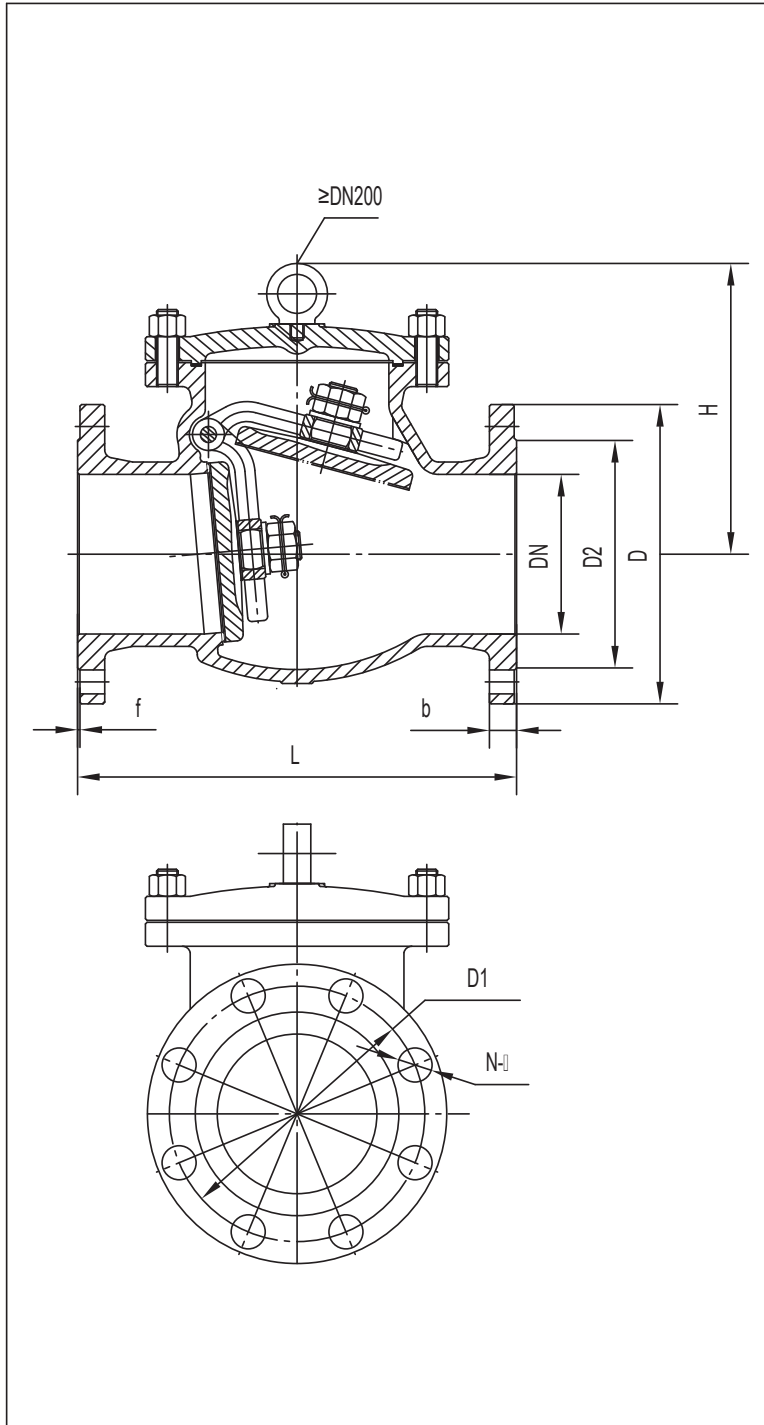

DPV Figure Numbers			
Material	DIN EN PN		
	PN40	PN63	PN100
Cast CS	4023F	6323F	10023F
Cast SS	4024F	6324F	10024F
Chrome Molys	4025F	6325F	10025F
Low Temp CS	4026F	6326F	10026F
Duplex	4027F	6327F	10027F
Super Duplex	4028F	6328F	10028F
Monel	4029F	6329F	10029F

PN40		Diameter (mm)								Weight(Kg)
DN	L	H	D	D1	D2	b	f	N-Ø		
50	230	190	165	125	102	20	3.0	4-18	*	
65	290	205	185	145	122	22	3.0	8-18	*	
80	310	220	200	160	138	24	3.0	8-18	*	
100	350	245	235	190	162	24	3.0	8-22	*	
125	400	265	270	220	188	26	3.0	8-26	*	
150	480	295	300	250	218	28	3.0	8-26	*	
200	600	330	375	320	285	34	3.0	12-30	*	
250	730	355	450	385	345	38	3.0	12-33	*	
300	850	395	515	450	410	42	4.0	16-30	*	
350	980	445	580	510	465	46	4.0	16-33	*	
400	1100	485	660	585	535	50	4.0	16-39	*	
450	1200	505	685	610	560	57	4.0	20-39	*	
500	1250	555	755	670	615	57	4.0	20-42	*	
600	1450	595	890	795	735	72	5.0	20-48	*	
PN63		Diameter (mm)								Weight(Kg)
DN	L	H	D	D1	D2	b	f	N-Ø		
50	300	405	180	135	102	26	3.0	4-22	*	
65	340	455	205	160	122	26	3.0	8-22	*	
80	380	605	215	170	138	28	3.0	8-22	*	
100	430	655	250	200	162	30	3.0	8-26	*	
125	500	720	295	240	188	34	3.0	8-30	*	
150	550	780	345	280	218	36	3.0	8-33	*	
200	650	875	415	345	285	42	3.0	12-36	*	
250	775	1260	470	400	345	46	3.0	12-36	*	
300	900	1480	530	460	410	52	4.0	16-36	*	
350	1025	1605	600	525	465	56	4.0	16-39	*	
400	1150	1790	670	585	535	60	4.0	16-42	*	
450	1275	*	*	*	*	*	*	*	*	
500	1400	2170	800	705	615	68	4.0	20-48	*	
600	1600	2600	930	820	735	76	5.0	20-56	*	
PN100		Diameter (mm)								Weight(Kg)
DN	L	H	D	D1	D2	b	f	N-Ø		
50	300	200	195	145	102	30	3.0	4-26	*	
65	340	215	220	170	122	34	3.0	8-26	*	
80	380	225	230	180	138	36	3.0	8-26	*	
100	430	261	265	210	162	40	3.0	8-30	*	
125	500	320	315	250	188	44	3.0	8-33	*	
150	550	340	355	290	218	44	3.0	12-33	*	
200	650	445	430	360	285	52	3.0	12-36	*	
250	775	490	505	430	345	60	3.0	12-39	*	
300	900	495	585	500	410	68	4.0	16-42	*	
350	1025	545	655	560	465	74	4.0	16-48	*	
400	1150	615	715	620	535	78	4.0	16-48	*	
500	1400	750	870	760	615	94	4.0	20-56	*	

## DPV-UK LTD.

Broadpiece, Mereside, Soham, Cambridgeshire, CB7 5EL  
England U. K

Ph. +44 (0) 1353 725 540

Fx. +44 (0) 1353 722 534

E-mail: [Sales@dpv\\_uk.com](mailto:Sales@dpv_uk.com)